

FluoroSeal



FMO-C GEAR OPERATOR

**ISO5211/IP65
DECLUTCHABLE OVERRIDE
GEAR OPERATOR**



The FMO-C series declutchable override gear box were specially designed to be used with butterfly valve, ball valve and plug valve jointly with pneumatic actuators.

This device allows for manual operation during installation, system testing and in the event of air supply failure.

MAIN FEATURES

- Simple, compact & light weight design
- Manufactured with cast iron housing
- ISO 5211 direct mounting patterns
- Easily selectable gear operator relative to valve, with two keyways 90° apart in the worm gear.
- Quick release mechanism from pneumatic to manual operation and back.
- Filled with special lubricant before leaving the factory
- Weatherproof: IP65
- Output torque ranges from 300Nm to 22100Nm

PARTS AND MATERIALS

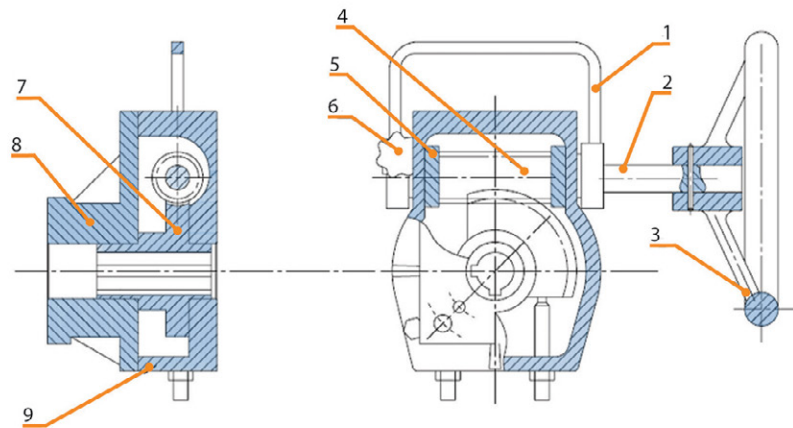

Item	Description	Material
1	Handle	Carbon steel
2	Worm Shaft	AISI 1045
3	Hand Wheel	Cast Iron HT200
4	Worm	AISI 1045
5	Eccentric Bushing Sub-assembly	Carbon steel
6	Stop Screw	Carbon steel
7	Worm Gear	Ductile Iron QT500-7
8	Bracket Cap	Cast Iron HT200
9	Body	Die-Cast Aluminium (for 26:1, 38:1, 54:1) or Cast Iron HT200 (for 80:1, 78:1, 98:1, 100:1, 118:1)

DIMENSIONS

FMO-C DECLUTCHABLE OVERRIDE GEAR OPERATOR

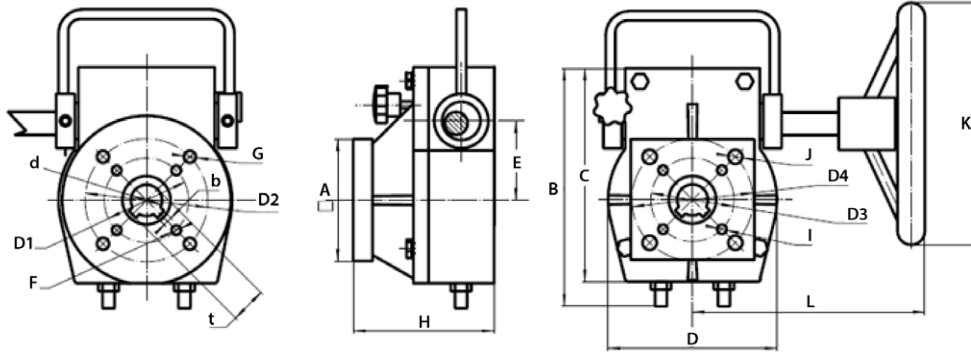

Model	d	b	t	D1	F	D2	G	A	H	E	D3	I	D4	J	K	L	B	C	D
	mm	mm	mm	mm		mm		mm	mm	mm	mm	mm	mm	mm	mm	mm	mm	mm	mm
FMO-C26:1	22	6	24.8	-	-	70	M8	70	99	50.5	-	-	70	Φ9	Φ200	155	160	145	110
FMO-C38:1	26	8	29.3	70	M8	102	M10	100	117	65	70	Φ9	102	Φ12	Φ200	195	195	175	140
	38	10	41.3	70	M8	102	-	110	117	65	70	Φ9	102	Φ12	Φ200	195	195	175	140
FMO-C54:1	38	10	41.3	125	M12	-	M16	130	118	85	125	Φ14	-	-	Φ300	205	235	215	180
	48	14	51.8	-	-	140	-	130	118	85	-	-	140	Φ18	Φ300	205	235	215	180
FMO-C80:1	48	14	51.8	140	M16	-	M20	156	148	124	140	Φ18	-	-	Φ400	245	320	298	250
	60	18	64.4	165	M20	165	M20	156	148	124	-	Φ22	165	Φ22	Φ400	245	320	298	250
FMO-C78:1	60	18	64.4	165	M20	-	-	220	150	142	165	Φ22	165	Φ22	Φ600	245	320	298	250
	80	22	85.6	-	-	-	-	220	150	142	-	-	-	-	Φ800	265	320	340	285
FMO-C98:1	80	22	85.6	165	M20	-	-	230	195	229	165	Φ22	-	-	Φ800	410	360	530	460
FMO-C100:1	100	28	106.6	254	M16	-	-	300	195	258	254	Φ18	-	-	Φ800	430	550	585	520
FMO-C118:1	120	32	129.3	356	M30	-	-	Φ445	250	391	356	Φ32	-	-	Φ1000	550	900	870	800
	180	45	196	483	M36	-	-	Φ600	275	390	483	Φ39	-	-	Φ600	600	1050	900	850

GEAR OPERATOR TORQUES & WEIGHT

Model	Gear Ratio	Input Torque		Output Torque		Weight	
		In-lbs	Nm	In-lbs	Nm	lbs	Kg
FMO-C26	26:1	620	70	2655	300	16	7.3
FMO-C38	38:1	531	60	4868	550	26	11.8
FMO-C54	54:1	1062	120	10621	1200	38	17.3
FMO-C80	80:1	1239	140	17701	2000	77	35
FMO-C78A	78:1	1770	200	31863	3600	106	48.2
FMO-C98	98:1	2655	300	79657	9000	344	156
FMO-C100	100:1	3540	400	115060	13000	419	190
FMO-C118	118:1	7966	900	195601	22100	1191	540

NOTES:

1. For all technical parameters of the product please refer to this catalog, additional information can be obtained from your local FluoroSeal sales office or authorized representative.
2. Customization for specific applications is available upon request.



USA

FluoroSeal U.S.A.
13350 South Gessner Rd.
Missouri City, TX, USA 77489
T: (281) 741-7855
F: (281) 741-3345
usasales@fluorosealvalves.com

NORTHERN EUROPE

FluoroSeal Europe GmbH
Künkelstr. 43 / Gebäude D5
D-41063 Mönchengladbach, Germany
T: 0049 2161 83905 70
F: 0049 2161 83905 77
slange@fluorosealvalves.com

CHINA

FluoroSeal Suzhou
1319 Jinfeng South Road
Suzhou 215101, China
T: 86 512 66389383
F: 86 512 66569571
chinasales@fluorosealvalves.com

EMEA

FluoroSeal EMEA
3 La Donna, Kfar Yassine
Beirut, Lebanon
T: +1 (514) 394-1056
T: + 33 1 76 35 01 88
F: + 1 (514) 739-5452
emeasales@fluorosealvalves.com

HEADQUARTERS

FluoroSeal Inc.
1875 46e Avenue
Lachine, QC, Canada H8T 2N8
TF: 1 888-269-0220 (Canada and U.S.A.)
T: (514) 739-0220
F: (514) 739-5452
sales@fluorosealvalves.com

www.fluorosealvalves.com