

FluoroSeal Inc.

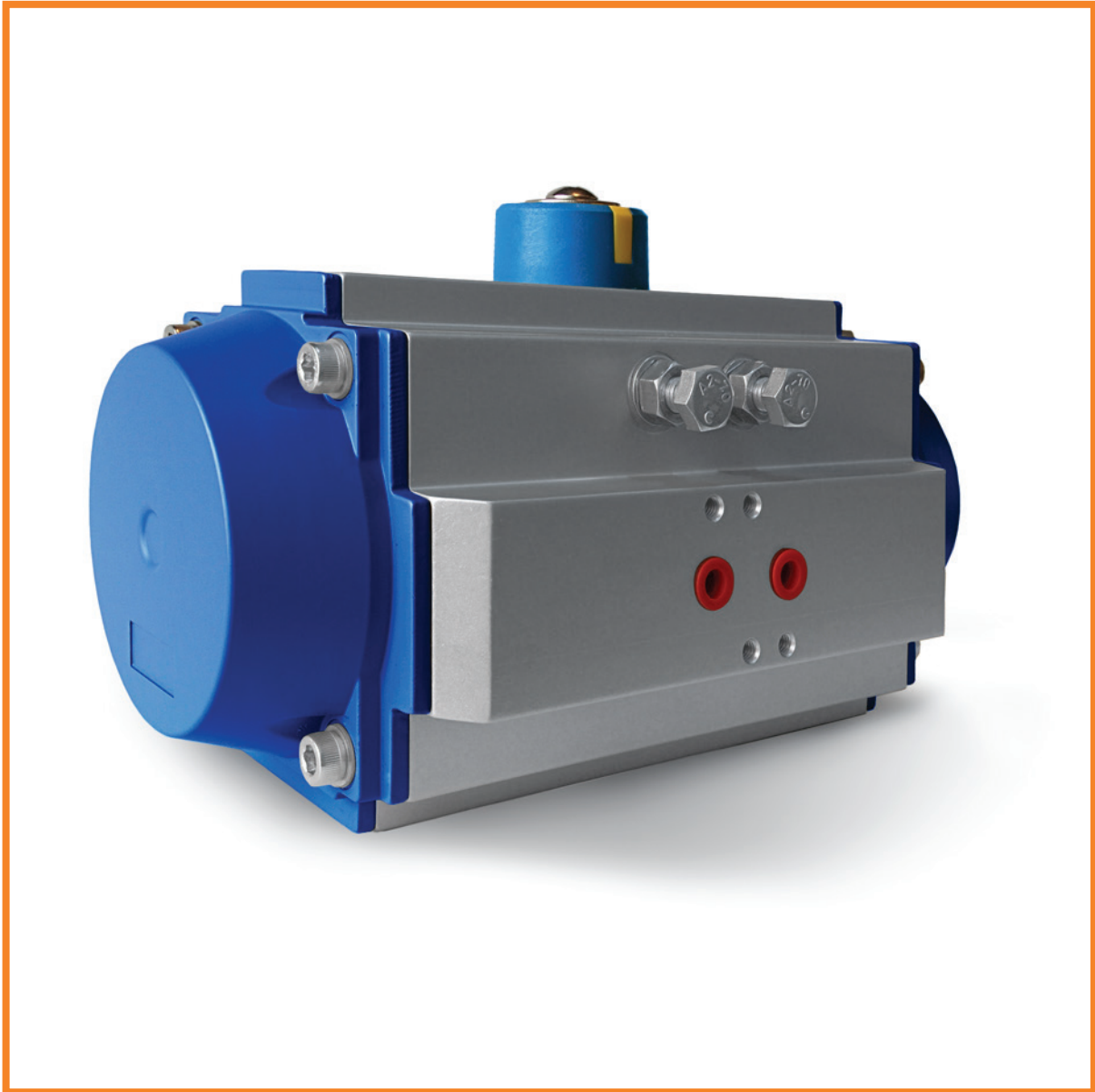

PNEUMATIC ACTUATORS

PNEUMATIC ACTUATORS CATALOG

TABLE OF CONTENTS

	Page
Design Features	1
Construction Characteristics	3
Components	4
Dimensions & Weights	5
Technical Data	9
Model Selection	19
Terms & Conditions	20

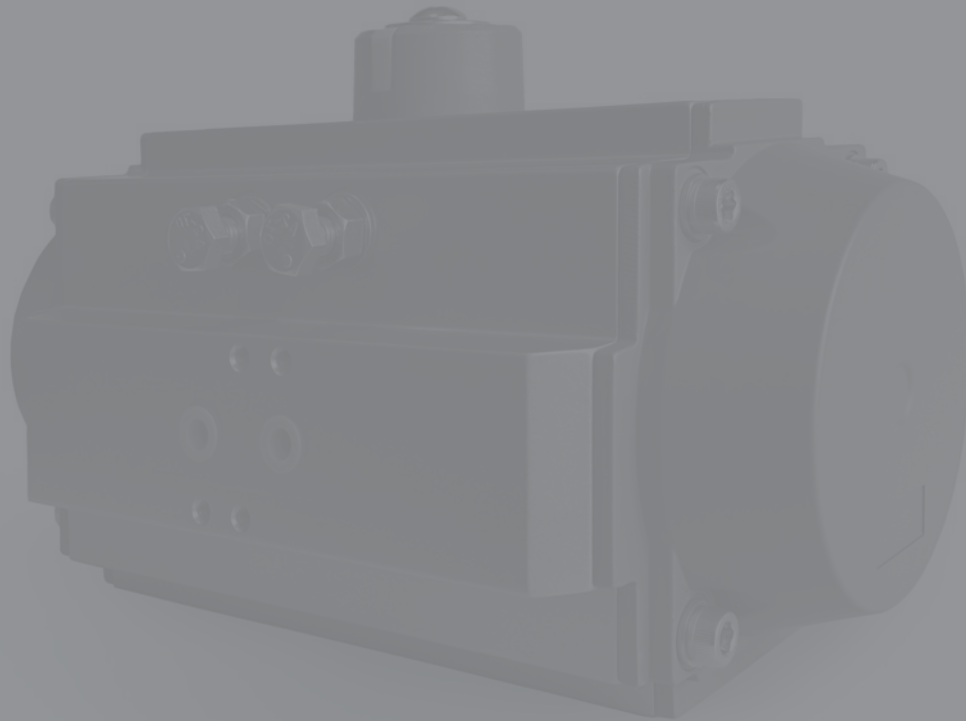

VALVE ACTUATORS FROM A VALVE MANUFACTURER



FluoroSeal Actuator Model FS095

FluoroSeal Inc. is a privately owned company with headquarters located in Montréal, QC, Canada and specializing in the manufacturing and servicing of a full range of industrial valves. Taking possession of all production and quality control processes, FluoroSeal Inc. is a vertically integrated company with manufacturing and sales locations throughout the world.

Always striving to streamline the customer’s procurement process, FluoroSeal has now added its own make of rack and pinion pneumatic actuators to its product range. This eliminates the extra work and selection on the customer’s part, offering a complete, functional and well-sized, fully-FluoroSeal warranted package in on-stop shopping.

The FluoroSeal® pneumatic rack and pinion actuators are designed, developed, and tested by FluoroSeal and incorporate the latest in technology and materials available on the market today. Thorough product and market research combined with over two decades of valve design and manufacturing, results in the highest quality actuators available.

PROVEN CHARACTERISTICS

- Long term reliability and precision are achieved through multiple bearings and guides on pistons and racks
- All moving parts are contained in Nylon bearings
- Preloaded Spring Cartridges for ease of installation and safe maintenance
- High performance and high reliability whether in critical isolation services or high cycling applications
- Full compliance to standards and specifications worldwide
- A comprehensive product range that permits the best sizing selection at a competitive cost
- Innovative universal drive shaft
- Multifunctional position indicator accepting a wide range of accessories
- Compact and modern design for various application environments

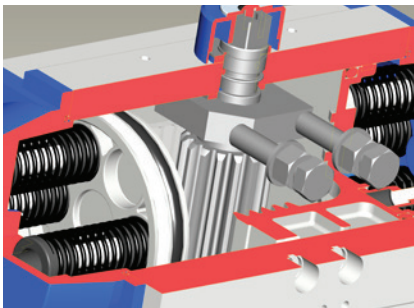

Universal Drive Shaft

DESIGN FEATURES

OPTIONS

- Stainless steel 420 drive shafts available upon request for all sizes for highly corrosive applications.
- All actuator models may be equipped with FPM or silicone O-rings in conjunction with a FluoroSeal tested and certified lubricant suitable for extremely high or low temperature applications.
- Customized drive connections as well as keyed drive or double "D" shape connections can be made in lieu of the standard double square bottom drive shaft connection

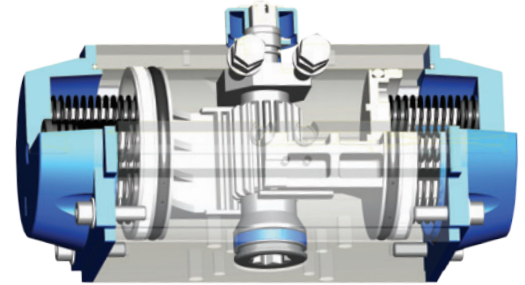

Customized Head Connections

COMMITMENT TO QUALITY

- All actuators conform to ISO 5211, DIN 3337, and VDI/VDE 3845 for product interchangeability and ease of solenoid, limit switch and accessory mounting.
- Produced in an ISO 9001 certified facility
- Each actuator component is made of superior quality materials
- Each individual actuator has been factory inspected and tested
- Each individual actuator is packaged separately, labelled accordingly and supplied with installation, operation and maintenance instructions

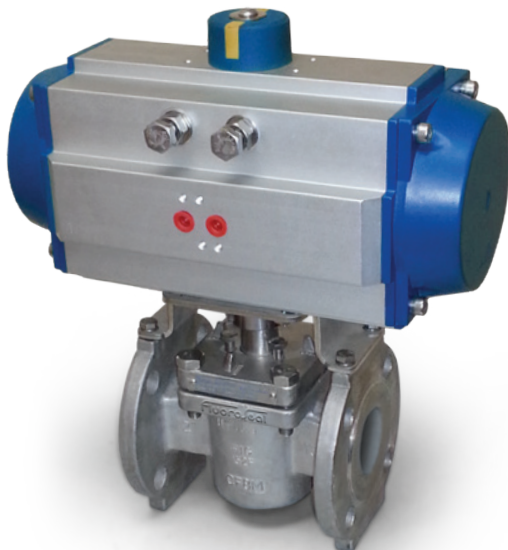
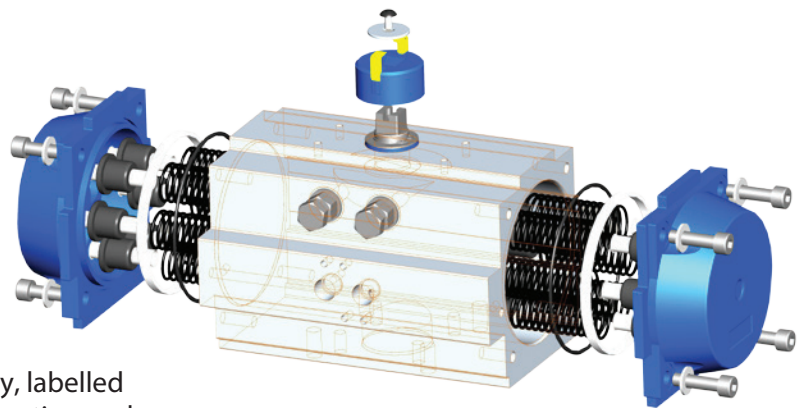

FluoroSeal FS095 Actuator
mounted on a FluoroSeal Plug Valve

AVAILABLE ACCESSORIES

- Different square reductions suitable for drive shaft
- Centering rings
- Brackets
- Couplings
- Solenoid valves
- Switch boxes
- Proximity switches
- Dec clutchable manual override gears
- Positioners

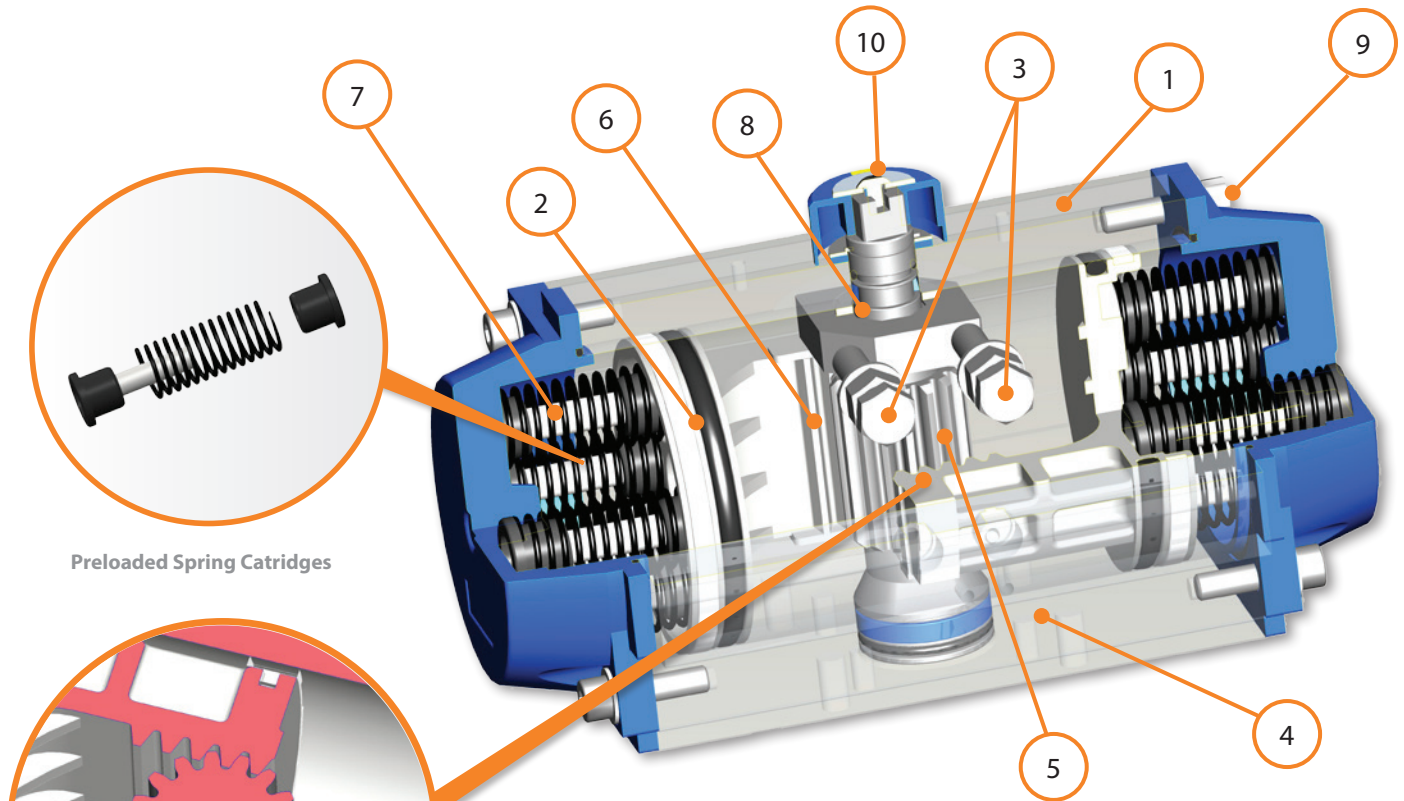

Preloaded Spring Cartridges

High Precision Teeth



Open/Closed Position Travel Stop Adjustment

CONSTRUCTION CHARACTERISTICS

1. A compact and lightweight extruded hard anodized aluminium body.
2. Dual piston rack and pinion design allows for compactness, symmetrical mounting, high cycle life and rapid operation. Reverse operation achieved through piston inversion.
3. Two external travel stop adjustments allow for a more accurate valve alignment through the independent +/- 4° adjustment, in either the closed or open position.
4. Multiple bearings and guides contain all moving parts.
5. One piece pinion shaft provides blowout protection and maximum cycle life.
6. Accurate positioning is achieved through high precision teeth on piston racks and pinion shaft that allows for maximum engagement and efficient operation.
7. Preloaded, modular spring cartridges are designed with coated springs offering range versatility, improved safety, and corrosion resistance.
8. High quality bearings and seals provide a wide operating temperature range, low friction, and high cycle life.
9. Internal and external stainless steel fasteners for long term corrosion resistance.
10. Colored visual position indication and a direct easy mount for sensors or accessories.

COMPONENTS

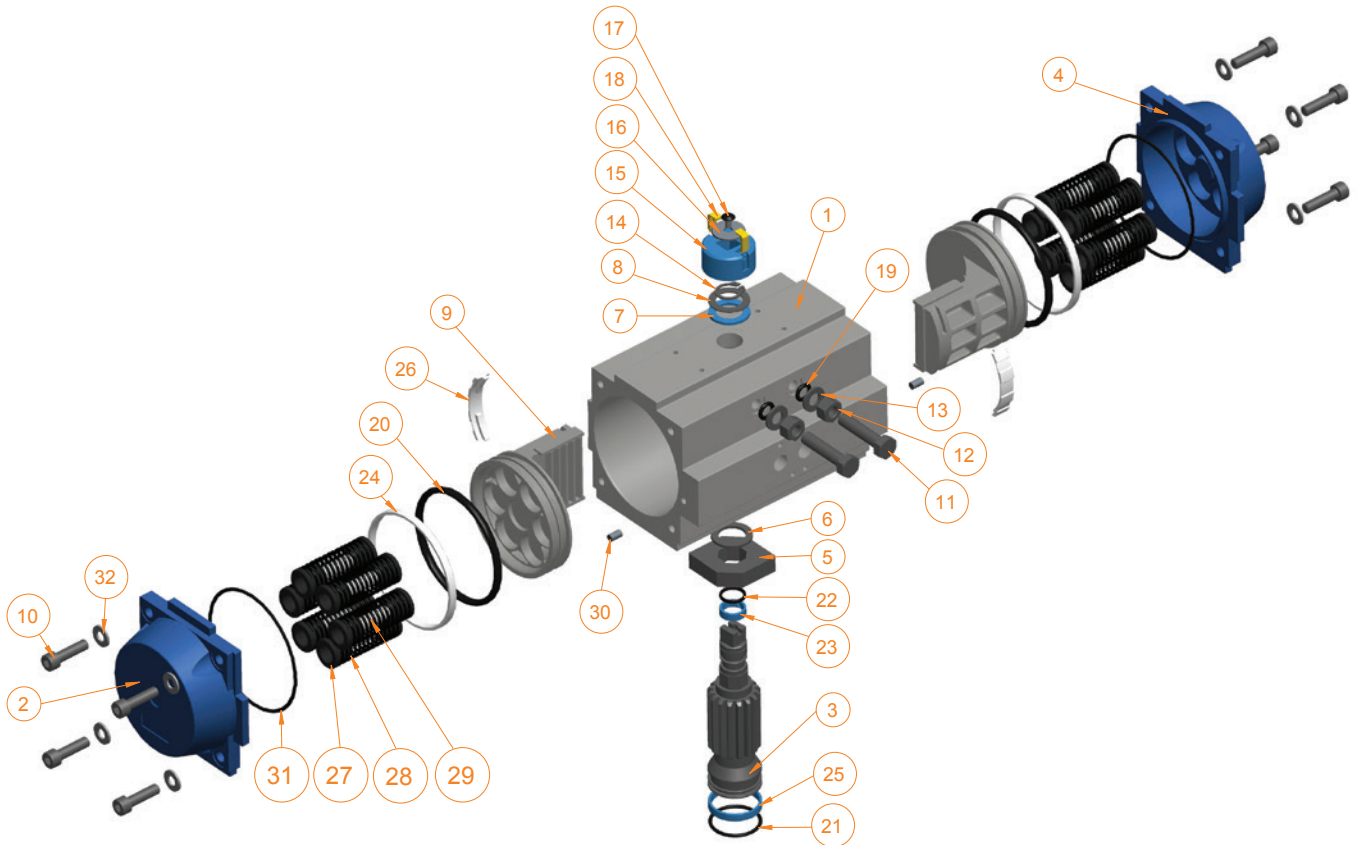

MATERIALS OF CONSTRUCTION

Item	Quantity		
1	1	Body	Aluminium Alloy, Hard Anodized
2	1	Left End Cap	Aluminium Alloy
3	1	Drive Shaft	Carbon Steel ENP (420 Stainless Steel Optional)
4	1	Right End Cap	Aluminium Alloy
5	1	Travel Stop Cam	Alloy Steel
6	1	Thrust Bearing (Pinion Cap)	Nylon
7	1	Thrust Bearing	Nylon
8	1	Thrust Washer	Stainless Steel
9	2	Piston	Aluminium Alloy
10	8	Cap Screw (End Cap)	Stainless Steel
11	2	Stop Screw	Stainless Steel
12	2	Nut (Stop Screw)	Stainless Steel
13	2	Washer (Stop Screw)	Stainless Steel
14	1	Spring Clip	Alloy Steel
15	1	Position Indicator	Nylon
16	1	Indicator Thrust Bearing	Stainless Steel
17	1	Cap Screw	Stainless Steel
18	2	Colour Code	Nylon
19	2	O-Ring (Stop Screw)	NBR
20	2	O-Ring (Piston)	NBR
21	1	O-Ring (Pinion Bottom)	NBR
22	1	O-Ring (Pinion Top)	NBR
23	1	Bearing (Pinion Top)	Nylon
24	2	Bearing (Pinion Head)	Nylon
25	1	Bearing (Pinion Bottom)	Nylon
26	2	Wear Band	Nylon
27	24	Spring Seat	Nylon
28	12	Spring	Stainless Steel
29	2	Straining Beam	Steel Alloy
30	2	Plug	NBR
31	2	O-Ring (End Cap)	NBR
32	8	Washer (End Cap)	Stainless Steel

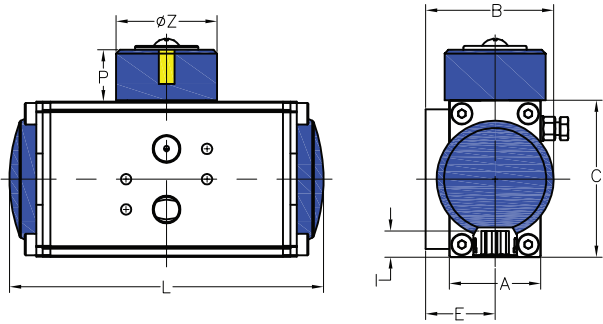

FS032

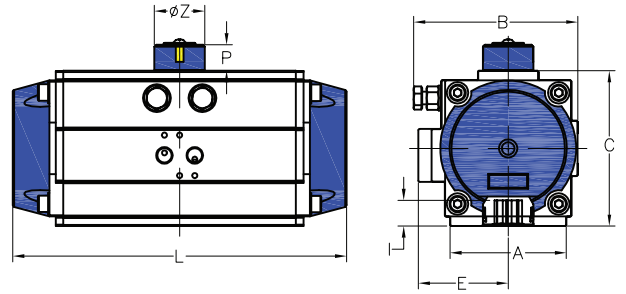

FS050-FS160

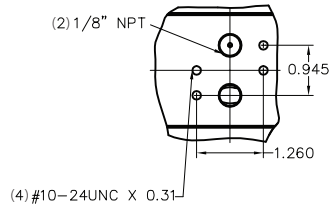

FS032
SIDE VIEW

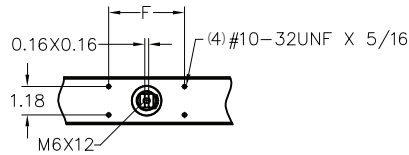

FS032-FS160
TOP VIEW

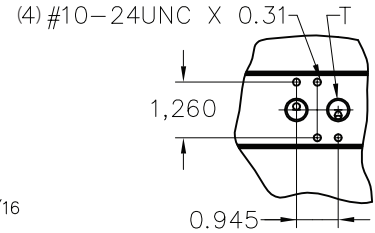

FS050-FS160
SIDE VIEW

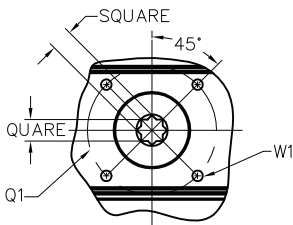

FS032
BOTTOM VIEW

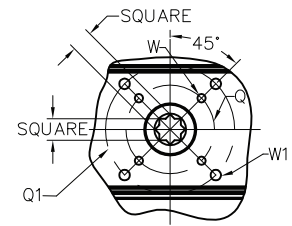

FS050-FS160
BOTTOM VIEW

Model	A	B	C	E	F	P	ØZ	L	I	Flange	Q	Q1	W	W1	Square	T
	in	in	in	in	in	in	in	in	in	ISO 5211	in	in	UNC	UNC	in	in
FS032	1.46	1.85	1.97	1.06	1.97	0.79	1.57	4.33	0.39	FA03	-	1.42	-	#10-24UNC x 0.35	0.4 x 0.4	1/8" NPT
FS050	1.77	2.78	2.76	1.63	3.15	0.79	1.57	6.06	0.47	FA03/05	1.42	1.97	#10-24UNC x 0.29	1/4"-20UNC x 0.35	0.4 x 0.4	1/4" NPT
FS065	2.44	3.52	3.50	2.03	3.15	0.79	1.57	7.44	0.63	FA05/07	1.97	2.76	1/4"-20UNC x 0.35	5/16"-18UNC x 0.47	0.6 x 0.6	1/4" NPT
FS075	2.68	4.04	3.94	2.32	3.15	0.79	1.57	8.27	0.63	FA05/07	1.97	2.76	1/4"-20UNC x 0.35	5/16"-18UNC x 0.47	0.6 x 0.6	1/4" NPT
FS085	2.68	4.43	4.45	2.50	3.15	0.79	1.57	9.02	0.75	FA05/07	1.97	2.76	1/4"-20UNC x 0.35	5/16"-18UNC x 0.47	0.7 x 0.7	1/4" NPT
FS095	3.62	4.96	4.84	2.80	3.15	0.79	1.57	10.39	0.75	FA05/07	2.76	4.02	1/4"-20UNC x 0.35	5/16"-18UNC x 0.47	0.7 x 0.7	1/4" NPT
FS110	3.66	5.45	5.35	3.01	3.15	0.79	1.57	10.47	0.75	FA07/10	2.76	4.02	5/16"-18UNC x 0.47	3/8"-16UNC x 0.59	0.7 x 0.7	1/4" NPT
FS125	3.78	6.18	6.34	3.35	3.15	1.18	2.20	13.27	0.98	FA07/10	2.76	4.02	5/16"-18UNC x 0.47	3/8"-16UNC x 0.59	0.9 x 0.9	1/4" NPT
FS140	4.33	7.01	7.01	3.82	3.15	1.18	2.20	14.84	1.22	FA10/12	4.02	4.92	3/8"-16UNC x 0.59	1/2"-13UNC x 0.71	1.1x1.1	1/4" NPT
FS160	4.41	7.72	7.87	4.17	5.12	1.18	2.20	16.22	1.22	FA10/12	4.02	4.92	3/8"-16UNC x 0.59	1/2"-13UNC x 0.71	1.1 x 1.1	1/4" NPT

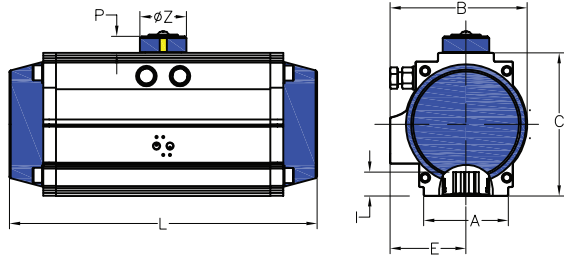

FS190-FS350

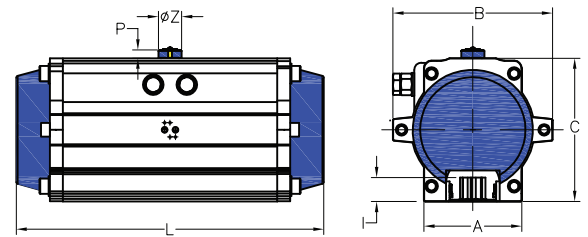

FS400

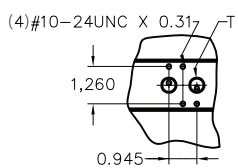

FS190-FS210

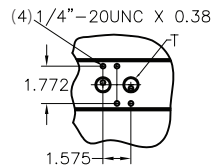

FS240-FS350

SIDE VIEW

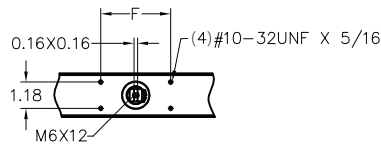

FS190-FS400

TOP VIEW

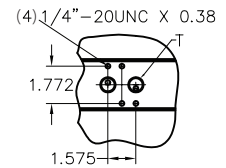

FS400

SIDE VIEW

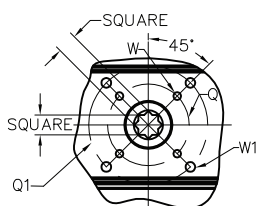

FS190

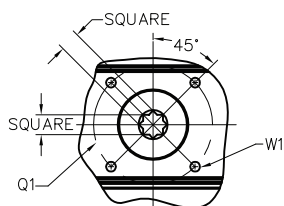

FS210-FS300

BOTTOM VIEW

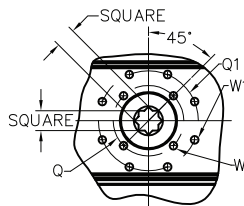

FS350

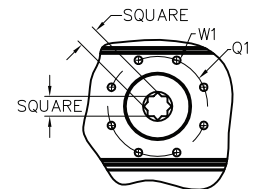

FS400

BOTTOM VIEW

Model	A in	B in	C in	E in	F in	P in	ØZ in	L in	I in	Flange ISO 5211	Q in	Q1 in	W UNC	W1 UNC	Square in	T in
FS190	5.35	8.52	9.13	4.41	5.12	1.18	2.20	19.21	1.61	FA10/14	4.02	5.51	4-3/8"-16UNC x 0.59	4-5/8"-11UNC x 0.94	1.4 x 1.4	1/4" NPT
FS210	5.51	9.27	10.04	4.72	5.12	1.18	3.15	21.65	1.57	FA14	-	5.51	-	4-5/8"-11UNC x 0.94	1.4x1.4	1/4" NPT
FS240	6.26	10.31	11.50	5.16	5.12	1.18	3.15	23.70	1.97	FA16	-	6.50	-	4-3/4"-10UNC x 1.10	1.8x1.8	1/2" NPT
FS270	6.26	11.61	13.03	5.81	5.12	1.18	3.15	26.46	1.97	FA16	-	6.50	-	4-3/4"-10UNC x 1.10	1.8 x 1.8	1/2" NPT
FS300	7.09	13.19	13.94	6.81	5.12	1.18	3.15	30.87	1.97	FA16	-	6.50	-	4-3/4"-10UNC x 1.10	1.8x1.8	1/2" NPT
FS350	10.63	15.16	16.14	7.68	5.12	1.18	3.15	33.27	1.97	FA16/25	6.50	10.00	4-3/4"-10UNC x 1.10	8-5/8"-11UNC x 1.19	1.8x1.8	1/2" NPT
FS400	11.42	20.47	18.35	10.24	5.12	1.18	3.15	37.64	2.36	FA25	-	10.00	-	8-5/8"-11UNC x 1.19	2.2x2.2	1/2" NPT

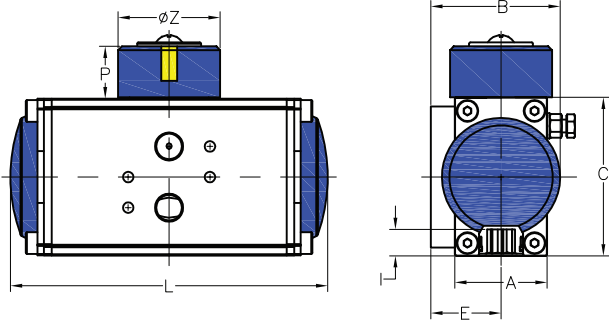

FM032

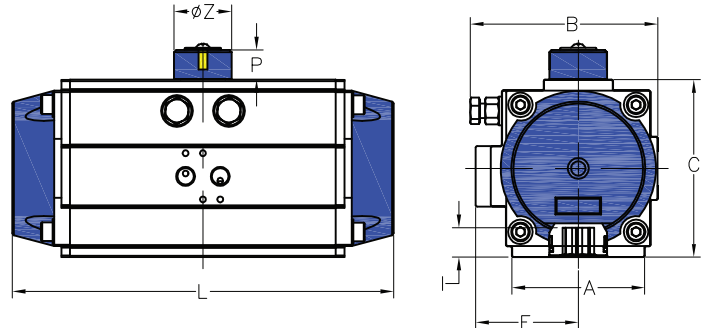

FM050-FM160

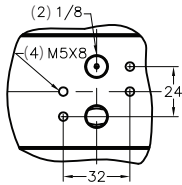

FM032
SIDE VIEW

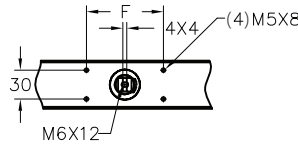

FM032-FM160
TOP VIEW

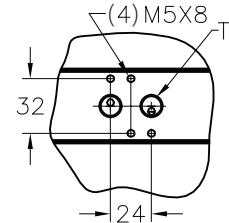

FM050-FM160
SIDE VIEW

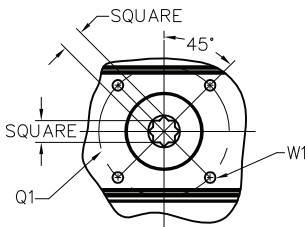

FM032
BOTTOM VIEW

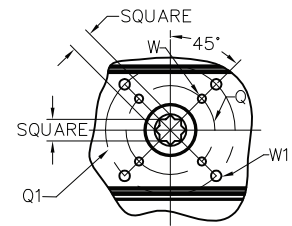

FM050-FM160
BOTTOM VIEW

Model	A	B	C	E	F	P	ØZ	L	I	Flange	Q	Q1	W	W1	Square	T
	mm	mm	mm	mm	mm	mm	mm	mm	mm	ISO 5211	mm	mm	mm	mm	mm	in
FM032	37	47	50	27	50	20	40	110	10	F03	-	36	-	M5 x 9	9x9	G 1/8"
FM050	45	70.5	70	41.5	80	20	40	154	12	F03/05	36	50	M5 x 7.5	M6 x 9	11x11	G 1/4"
FM065	62	89.5	89	51.5	80	20	40	189	16	F05/07	50	70	M6 x 9	M8 x 12	14x14	G 1/4"
FM075	68	102.5	100	59	80	20	40	210	16	F05/07	50	70	M6 x 9	M8 x 12	14x14	G 1/4"
FM085	68	112.5	113	63.5	80	20	40	229	19	F05/07	50	70	M6 x 9	M8 x 12	17x17	G 1/4"
FM095	92	126	123	71	80	20	40	264	19	F05/07	70	102	M6 x 9	M8 x 12	17x17	G 1/4"
FM110	93	138.5	136	76.5	80	20	40	266	19	F07/10	70	102	M8 x 12	M10 x 15	17x17	G 1/4"
FM125	96	157	161	85	80	30	56	337	25	F07/10	70	102	M8 x 12	M10 x 15	22x22	G 1/4"
FM140	110	178	178	97	80	30	56	377	31	F10/12	102	125	M10 x 15	M12 x 18	27x27	G 1/4"
FM160	112	196	200	106	130	30	56	412	31	F10/12	102	125	M10 x 15	M12 x 18	27x27	G 1/4"

METRIC DIMENSIONS

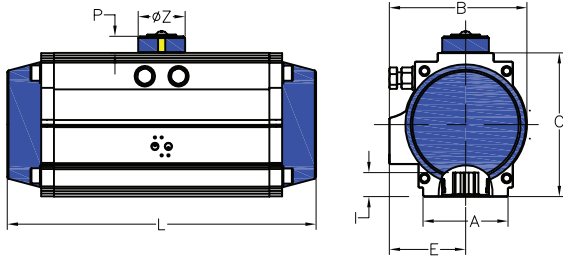

FM190-FM350

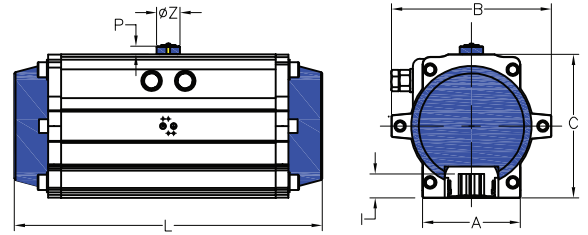

FM400

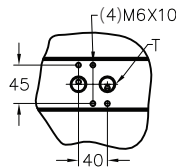
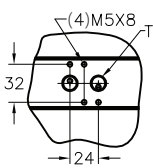

FM190-FM210 FM240-FM350
SIDE VIEW

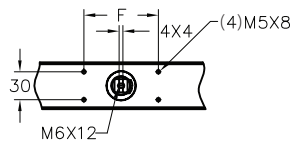

FM190-FM400
TOP VIEW

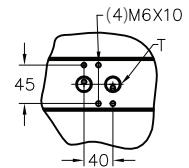

FM400
SIDE VIEW

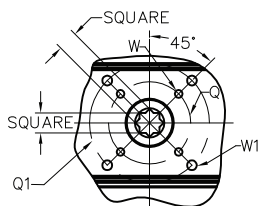

FM190

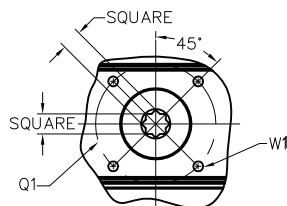

FM210-FM300
BOTTOM VIEW

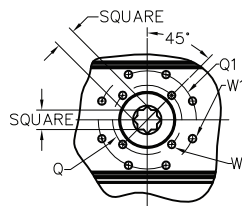

FM350

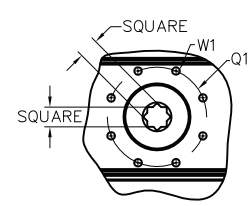

FM400
BOTTOM VIEW

Model	A	B	C	E	F	P	ØZ	L	I	Flange	Q	Q1	W	W1	Square	T
	mm	mm	mm	mm	mm	mm	mm	mm	mm	ISO 5211	mm	mm	mm	mm	mm	in
FM190	136	216.5	232	112	130	30	56	488	41	F10/14	102	140	M10 x 15	M16X24	36X36	G 1/4"
FM210	140	235.5	255	120	130	30	80	550	40	F14	-	140	-	M16X24	36X36	G 1/4"
FM240	159	262	292	131	130	30	80	602	50	F16	-	165	-	M20X28	46X46	G 1/2"
FM270	159	295	331	147.5	130	30	80	672	50	F16	-	165	-	M20X28	46X46	G 1/2"
FM300	180	335	354	173	130	30	80	784	50	F16	-	165	-	M20X28	46X46	G 1/2"
FM350	270	385	410	195	130	30	80	845	50	F16/F25	165	254	M20 x 28	M16X30	46X46	G 1/2"
FM400	290	520	466	260	130	30	80	956	60	F25	-	254	-	M16X30	55X55	G 1/2"

FluoroSeal Inc.

Specialty Valves



PNEUMATIC-ACTUATORS-R007-2019

TECHNICAL DATA

TORQUE RATINGS — IMPERIAL

Torque diagram — double acting actuators

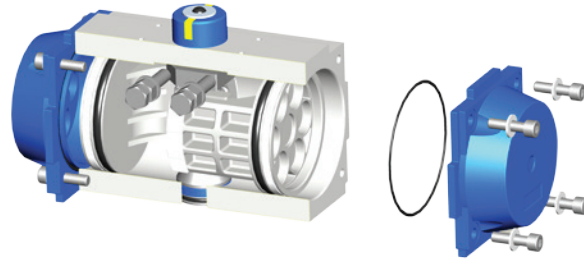
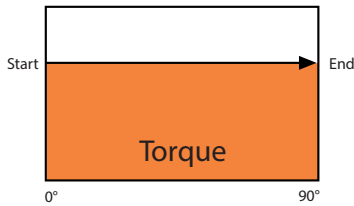

Model	DOUBLE ACTING TORQUE RATINGS (In.lbs)					
	Air Supply Pressure (psig)					
	40	50	60	80	100	115
FS032 D	29	36	45	58	73	84
FS050 D	86	108	131	176	223	258
FS065 D	172	221	266	356	452	522
FS075 D	267	342	413	552	703	812
FS085 D	392	501	606	810	1029	1192
FS095 D	550	704	851	1138	1452	1675
FS110 D	710	924	1118	1485	1891	2178
FS125 D	1268	1650	1987	2652	3369	3890
FS140 D	1932	2446	2948	3915	4971	5730
FS160 D	2597	3378	4074	5430	6906	7968
FS190 D	4223	5344	6438	8543	10839	12497
FS210 D	5895	7459	8988	11926	15141	17447
FS240 D	9148	11569	13929	18501	23481	27064
FS270 D	12860	16267	19592	26010	33017	38054
FS300 D	16541	20932	25207	33466	42475	48958
FS350 D	24560	31066	37409	49667	63043	72660
FS400 D	37425	47338	57010	75682	96069	110719

NOTES:
 Max. Operating Pressure 115 psig.
 Design Pressure Rating 175 psig.

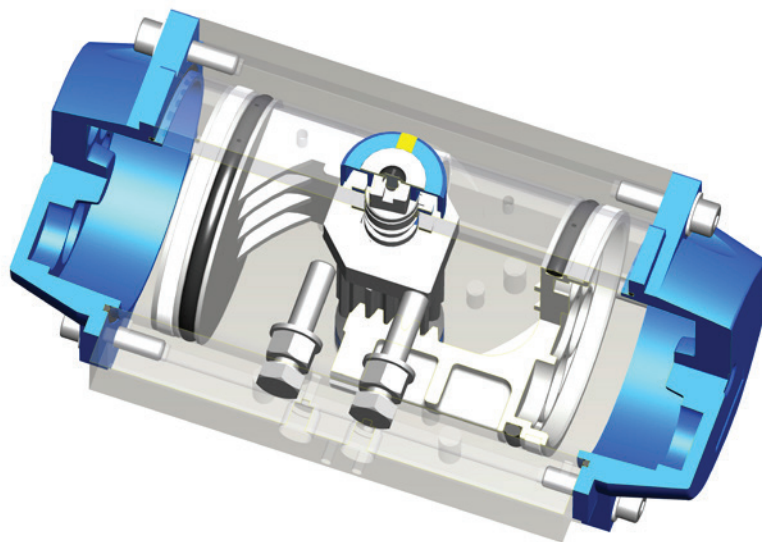

FluoroSeal Double Acting Actuator
 Model FS095D

PNEUMATIC-ACTUATORS-R007-2019

TORQUE RATINGS — IMPERIAL

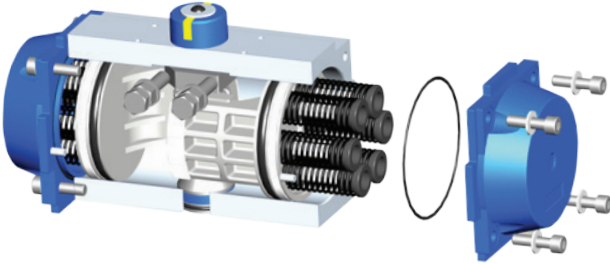

Torque diagram — spring return actuators

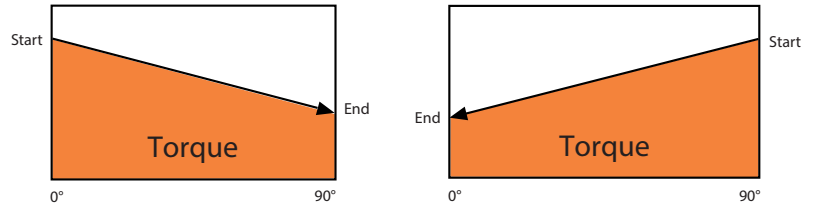

SPRING RETURN TORQUE RATINGS (In.lbs)												
Model	Air Supply Pressure (Unit: psig)										Spring Stroke	
	40		60		80		100		115			
	START 0°	END 90°	START 0°	END 90°	START 0°	END 90°	START 0°	END 90°	START 0°	END 90°	START 90°	END 0°
FS050 S05	53	39	100	85							46	31
FS050 S06	47	30	94	76	138	120					55	37
FS050 S07	41	21	88	67	132	112					64	43
FS050 S08			81	58	126	102	175	151			73	50
FS050 S09			75	49	120	93	169	143	202	175	82	56
FS050 S10			69	40	113	84	163	134	196	166	91	62
FS050 S11					107	74	157	124	190	158	100	68
FS050 S12					101	66	150	115	183	148	110	74
FS065 S05	94	55	187	148							116	77
FS065 S06	79	32	172	125	263	216					139	92
FS065 S07	63	9	156	102	247	193					162	108
FS065 S08			141	78	232	169	332	270			186	123
FS065 S09			127	55	216	146	317	247	384	314	209	139
FS065 S10			112	32	201	123	301	223	368	290	232	154
FS065 S11					185	100	286	200	353	267	255	169
FS065 S12					170	77	271	177	337	244	278	185

NOTES:
Max. Operating Pressure 115 psig.
Design Pressure Rating 170 psig.

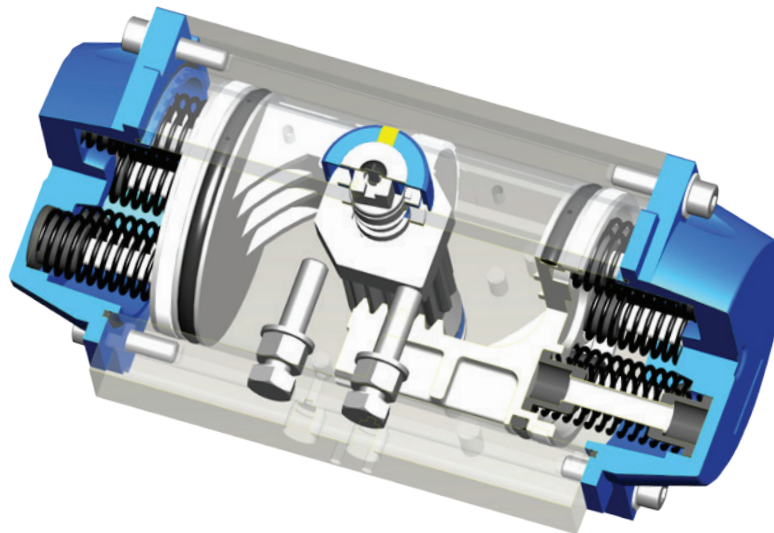

FluoroSeal Spring Return Actuator
Model FS095 S12

TECHNICAL DATA



Model	Air Supply Pressure (psig)										Spring Stroke	
	40		60		80		100		115		START	END
	START	END	START	END	START	END	START	END	START	END		
	0°	90°	0°	90°	0°	90°	0°	90°	0°	90°	90°	0°
FS075 S05	171	116	317	262							150	95
FS075 S06	152	87	299	233	438	373					179	113
FS075 S07	134	58	279	203	419	343					209	133
FS075 S08			261	173	400	313	556	469			239	151
FS075 S09			242	144	381	283	538	439	641	543	268	172
FS075 S10			224	114	362	253	518	409	623	514	298	190
FS075 S11					343	223	499	379	603	484	329	208
FS075 S12					324	193	480	350	585	453	358	228
FS085 S05	244	159	457	368							231	147
FS085 S06	213	112	428	322	634	533					277	176
FS085 S07	183	66	399	276	605	487					323	205
FS085 S08			369	230	575	440	804	670			369	235
FS085 S09			340	184	546	394	775	623	928	777	415	264
FS085 S10			311	138	516	348	746	577	899	731	461	293
FS085 S11					487	302	716	531	869	684	507	322
FS085 S12					458	256	687	485	840	638	553	352
FS095 S05	352	239	653	538							309	196
FS095 S06	313	177	614	477	903	768					370	235
FS095 S07	272	115	575	415	864	706					432	274
FS095 S08			535	353	825	644	1147	966			494	314
FS095 S09			497	292	786	583	1108	904	1322	1119	555	352
FS095 S10			457	230	747	521	1068	842	1283	1057	617	392
FS095 S11					708	459	1029	781	1244	995	679	430
FS095 S12					668	397	990	719	1204	933	740	469
FS110 S05	461	308	858	707							406	253
FS110 S06	411	228	807	626	1181	997					487	304
FS110 S07	360	147	757	544	1130	916					569	354
FS110 S08			705	463	1080	835	1496	1251			650	406
FS110 S09			655	383	1028	754	1444	1170	1723	1447	730	456
FS110 S10			604	301	978	672	1394	1088	1671	1366	812	507
FS110 S11					927	591	1343	1007	1621	1285	894	557
FS110 S12					877	510	1293	926	1570	1204	974	608
FS125 S05	824	563	1528	1272							714	452
FS125 S06	734	420	1438	1130	2110	1795					856	542
FS125 S07	644	276	1348	989	2019	1653					999	632
FS125 S08			1257	846	1929	1510	2672	2253			1142	723
FS125 S09			1167	704	1839	1367	2582	2110	3077	2606	1284	813
FS125 S10			1077	561	1748	1225	2491	1968	2987	2464	1427	903
FS125 S11					1658	1082	2401	1825	2897	2321	1569	994
FS125 S12					1568	940	2311	1683	2806	2179	1712	1084
FS140 S05	1193	838	2212	1858							1084	729
FS140 S06	1047	621	2067	1642	3040	2614					1300	874
FS140 S07	902	404	1921	1425	2895	2397					1517	1020
FS140 S08			1776	1208	2749	2180	3836	3268			1734	1165
FS140 S09			1629	992	2604	1964	3690	3052	4416	3776	1950	1312
FS140 S10			1484	775	2458	1747	3545	2835	4269	3559	2167	1457
FS140 S11					2312	1530	3399	2618	4124	3343	2384	1603
FS140 S12					2166	1314	3254	2401	3978	3126	2600	1748
FS160 S05	1639	1177	3087	2627							1437	974
FS160 S06	1444	889	2892	2340	4261	3705					1724	1169
FS160 S07	1250	601	2697	2052	4066	3418					2012	1364
FS160 S08			2502	1765	3871	3131	5393	4653			2299	1559
FS160 S09			2308	1477	3676	2844	5198	4366	6214	5381	2587	1753
FS160 S10			2113	1190	3481	2556	5004	4078	6019	5094	2874	1948
FS160 S11					3286	2269	4809	3791	5825	4806	3162	2143
FS160 S12					3092	1981	4614	3503	5630	4519	3449	2338

PNEUMATIC ACTUATORS-R007-2019

Model	Air Supply Pressure (psig)										Spring Stroke	
	40		60		80		100		115		START	END
	START	END	START	END	START	END	START	END	START	END		
	0°	90°	0°	90°	0°	90°	0°	90°	0°	90°		
FS190 S05	2582	1879	4808	4099							2313	1610
FS190 S06	2260	1416	4486	3637	6611	5767					2775	1932
FS190 S07	1938	953	4164	3174	6289	5305					3238	2254
FS190 S08			3843	2712	5967	4842	8340	7215			3700	2575
FS190 S09			3520	2249	5645	4379	8017	6752	9600	8334	4163	2898
FS190 S10			3199	1787	5323	3917	7696	6290	9278	7871	4625	3219
FS190 S11					5001	3454	7374	5827	8956	7409	5088	3542
FS190 S12					4680	2992	7052	5364	8634	6947	5551	3868
FS210 S05	3678	2671	6782	5773							3180	2173
FS210 S06	3243	2035	6347	5137	9318	8109					3816	2608
FS210 S07	2808	1399	5912	4501	8883	7474					4452	3043
FS210 S08			5478	3864	8449	6838	11762	10151			5089	3477
FS210 S09			5043	3228	8014	6202	11327	9514	13536	11723	5725	3912
FS210 S10			4608	2593	7579	5565	10892	8878	13101	11087	6360	4347
FS210 S11					7145	4929	10457	8242	12666	10451	6996	4781
FS210 S12					6710	4293	10023	7606	12231	9815	7632	5216
FS240 S05	5442	4171	10258	8983							4906	3635
FS240 S06	4715	3190	9531	8002	14135	12610					5887	4362
FS240 S07	3988	2209	8803	7020	13408	11629					6869	5090
FS240 S08			8076	6039	12681	10648	17819	15786			7850	5817
FS240 S09			7349	5058	11954	9666	17092	14805	20518	18230	8831	6544
FS240 S10			6622	4077	11227	8685	16365	13823	19791	17249	9812	7271
FS240 S11					10500	7704	15638	12842	19063	16268	10794	7998
FS240 S12					9773	6723	14911	11861	18336	15286	11775	8725
FS270 S05	7810	5804	14585	12574							6961	4955
FS270 S06	6819	4412	13594	11182	20066	17632					8353	5946
FS270 S07	5828	3020	12603	9790	19075	16267					9745	6937
FS270 S08			11611	8398	18084	14875	25310	22100			11137	7929
FS270 S09			10621	7006	17092	13482	24319	20708	29135	25525	12529	8919
FS270 S10			9630	5613	16102	12090	23328	19316	28144	24133	13922	9910
FS270 S11					15111	10698	22337	17924	27153	22740	15314	10901
FS270 S12					14120	9306	21346	16532	26162	21348	16706	11892
FS300 S05	10299	7281	19016	15995							9138	6120
FS300 S06	9075	5453	17792	14167	26121	22500					10966	7344
FS300 S07	7851	3625	16568	12339	24897	20672					12794	8568
FS300 S08			15343	10512	23673	18844	32969	28140			14621	9793
FS300 S09			14119	8684	22449	17016	31745	26312	37943	32509	16449	11017
FS300 S10			12895	6856	21225	15189	30520	24484	36718	30682	18277	12241
FS300 S11					20000	13361	29297	22657	35494	28855	20105	13465
FS300 S12					18777	11533	28073	20829	34270	27027	21933	14689
FS350 S05	15568	11307	28499	24239							13067	8806
FS350 S06	13807	8694	26738	21626	39099	33987					15680	10567
FS350 S07	12045	6081	24977	19013	37339	31373					18293	12328
FS350 S08			23216	16400	35577	28760	49373	42556			20906	14089
FS350 S09			21455	13786	33817	26146	47612	39942	56809	49140	23520	15850
FS350 S10			19694	11173	32055	23533	45851	37329	55049	46527	26133	17611
FS350 S11			17933	8559	30294	20920	44090	34716	53287	43913	28747	19373
FS350 S12			16172	5946	28533	18306	42329	32102	51527	41300	31360	21133
FS400 S05	23181	16760	42888	36467							20378	13957
FS400 S06	20391	12686	40098	32394	58937	51232					24451	16747
FS400 S07	17601	8612	37309	28320	56138	47149					28525	19536
FS400 S08			34520	24237	53348	43076	74373	64100			32608	22335
FS400 S09			31731	20163	50559	39002	71583	60026	85593	74036	36682	25124
FS400 S10			28941	16090	47769	34928	68793	55952	82804	69962	40755	27914
FS400 S11			26151	12016	44980	30854	65995	51870	80014	65889	44829	30704
FS400 S12			23362	7942	42181	26772	63205	47796	77224	61815	48903	33493

PNEUMATIC-ACTUATORS-R007-2019

TORQUE RATINGS — METRIC

Torque diagram — double acting actuators

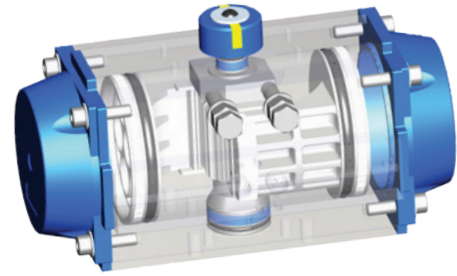
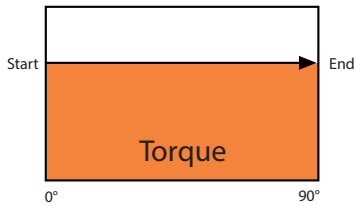

DOUBLE ACTING TORQUE RATINGS (Nm)						
Model	Air Supply Pressure (barg)					
	3	4	5	6	7	8
FM032 D	3.4	4.6	5.9	7.1	8.3	9.5
FM050 D	10.4	14.2	17.9	21.6	25.4	29.1
FM065 D	21.2	28.7	36.3	43.9	51.4	59
FM075 D	32.9	44.7	56.4	68.2	79.9	91.7
FM085 D	48.3	65.6	82.8	100	117	135
FM095 D	67.9	92.1	116	141	165	189
FM110 D	89.3	121	152	183	215	246
FM125 D	159	215	271	327	383	439
FM140 D	237	319	401	483	565	647
FM160 D	327	441	556	670	785	900
FM190 D	518	697	875	1054	1232	1411
FM210 D	723	973	1222	1471	1721	1970
FM240 D	1122	1508	1895	2282	2669	3056
FM270 D	1577	2121	2665	3209	3753	4297
FM300 D	2029	2729	3429	4129	4828	5528
FM350 D	3012	4050	5089	6127	7166	8205
FM400 D	4589	6172	7755	9337	10920	12502

NOTES:
Max. Operating Pressure 8 barg.
Design Pressure Rating 12 barg.

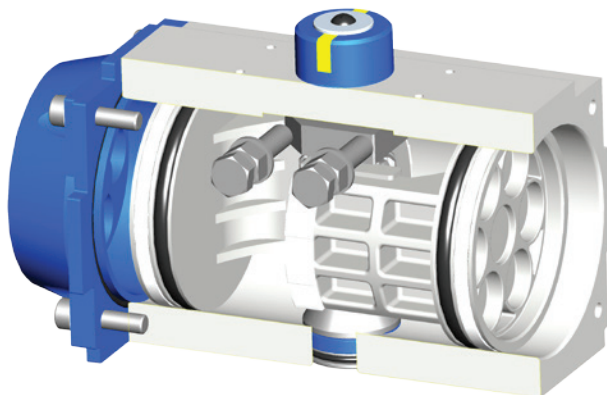

FluoroSeal Double Acting Actuator
Model FS095D

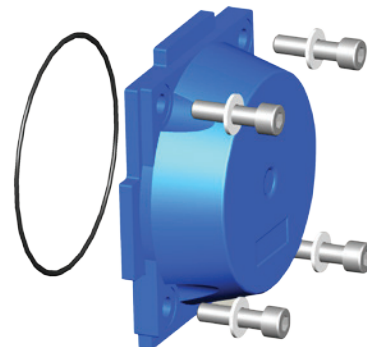

PNEUMATIC-ACTUATORS-R007-2019

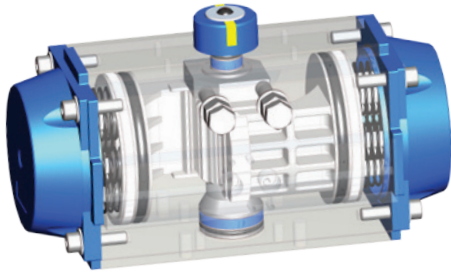

TORQUE RATINGS — METRIC

Torque diagram — spring return actuators

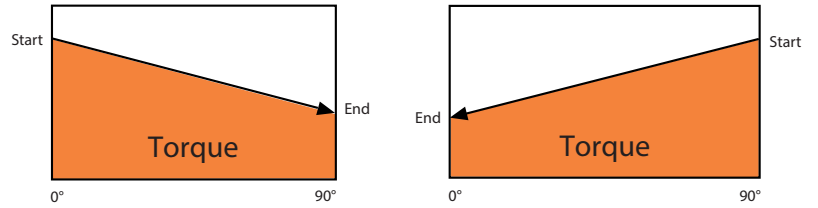

SPRING RETURN TORQUE RATINGS (Nm)

Model	Air Supply Pressure (Unit: barg)												Spring Stroke	
	3		4		5		6		7		8			
	START 0°	END 90°	START 0°	END 90°	START 0°	END 90°	START 0°	END 90°	START 0°	END 90°	START 0°	END 90°	START 90°	END 0°
FM050 S05	6.9	5.3	10.7	9.0	14.4	12.8							5.2	3.5
FM050 S06	6.2	4.3	10.0	8.0	13.7	11.7							6.2	4.2
FM050 S07	5.5	3.2	9.3	7.0	13.0	10.7	16.7	14.4					7.2	4.9
FM050 S08			8.6	5.9	12.3	9.7	16.0	13.4	19.8	17.1			8.2	5.6
FM050 S09			7.9	4.9	11.6	8.6	15.3	12.4	19.1	16.1	22.8	19.8	9.3	6.3
FM050 S10					10.9	7.6	14.6	11.3	18.4	15.1	22.1	18.8	10.3	7.0
FM050 S11					10.2	6.6	13.9	10.3	17.7	14.0	21.4	17.8	11.3	7.7
FM050 S12							13.2	9.3	17.0	13.0	20.7	16.7	12.4	8.4
FM065 S05	12.5	8.1	20.0	15.6	27.6	23.2							13.1	8.7
FM065 S06	10.7	5.5	18.3	13.0	25.9	20.6							15.7	10.4
FM065 S07	9.0	2.8	16.6	10.4	24.1	18.0	31.7	25.5					18.3	12.2
FM065 S08			14.8	7.8	22.4	15.4	30.0	22.9	37.5	30.5			21.0	13.9
FM065 S09			13.1	5.2	20.7	12.7	28.2	20.3	35.8	27.9	43.4	35.4	23.6	15.7
FM065 S10					18.9	10.1	26.5	17.7	34.0	25.2	41.6	32.8	26.2	17.4
FM065 S11					17.2	7.5	24.7	15.1	32.3	22.6	39.9	30.2	28.8	19.1
FM065 S12							23.0	12.4	30.6	20.0	38.1	27.6	31.4	20.9

NOTES:
Max. Operating Pressure 8 barg.
Design Pressure Rating 12 barg.

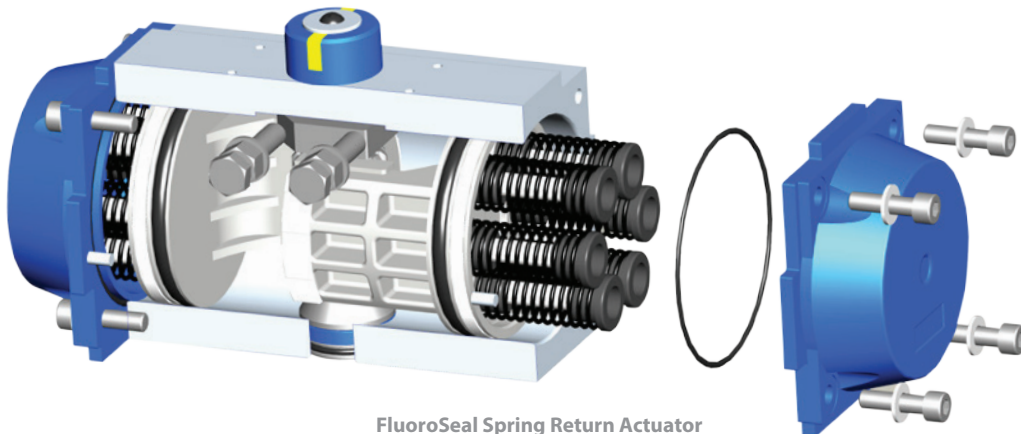

FluoroSeal Spring Return Actuator
Model F5095 S12

TECHNICAL DATA



Model	Air Supply Pressure (Unit: barg)												Spring Stroke	
	3		4		5		6		7		8			
	START	END	START	END	START	END	START	END	START	END	START	END	START	END
	0°	90°	0°	90°	0°	90°	0°	90°	0°	90°	0°	90°	90°	0°
FM075 S05	22.2	16.0	34.0	27.8	45.7	39.6							16.9	10.7
FM075 S06	20.1	12.7	31.8	24.4	43.6	36.2							20.2	12.8
FM075 S07	17.9	9.3	29.7	21.1	41.4	32.8	53.2	44.6					23.6	15.0
FM075 S08			27.5	17.7	39.3	29.4	51.0	41.2	62.8	53.0			27.0	17.1
FM075 S09			25.4	14.3	37.1	26.1	48.9	37.8	60.7	49.6	72.4	61.3	30.3	19.3
FM075 S10					35.0	22.7	46.8	34.5	58.5	46.2	70.3	58.0	33.7	21.4
FM075 S11					32.9	19.3	44.6	31.1	56.4	42.8	68.1	54.6	37.1	23.5
FM075 S12							42.5	27.7	54.2	39.5	66.0	51.2	40.4	25.7
FM085 S05	32	22	49	39	66	57							26	17
FM085 S06	28	17	46	34	63	51							31	20
FM085 S07	25	12	42	29	60	46	77	64					36	23
FM085 S08			39	24	56	41	74	58	91	76			42	26
FM085 S09			36	19	53	36	70	53	87	70	105	88	47	30
FM085 S10					50	31	67	48	84	65	101	82	52	33
FM085 S11					46	26	64	43	81	60	98	77	57	36
FM085 S12							60	38	78	55	95	72	62	40
FM095 S05	46	33	70	57	94	81							35	22
FM095 S06	41	26	66	50	90	74							42	26
FM095 S07	37	19	61	43	85	68	110	92					49	31
FM095 S08			57	36	81	61	105	85	129	109			56	35
FM095 S09			52	29	77	54	101	78	125	102	149	126	63	40
FM095 S10					72	47	96	71	121	95	145	119	70	44
FM095 S11					68	40	92	64	116	88	141	112	77	49
FM095 S12							88	57	112	81	136	105	84	53
FM110 S05	61	43	92	75	123	106							46	29
FM110 S06	55	34	86	66	118	97							55	34
FM110 S07	49	25	81	56	112	88	143	119					64	40
FM110 S08			75	47	106	79	137	110	169	141			73	46
FM110 S09			69	38	100	69	132	101	163	132	194	163	82	51
FM110 S10					95	60	126	92	157	123	189	154	92	57
FM110 S11					89	51	120	82	152	114	183	145	101	63
FM110 S12							115	73	146	105	177	136	110	69
FM125 S05	108	79	164	135	220	191							81	51
FM125 S06	98	63	154	119	210	175							97	61
FM125 S07	88	47	144	103	200	159	256	215					113	71
FM125 S08			134	87	190	142	246	198	302	254			129	82
FM125 S09			124	71	180	126	236	182	291	238	347	294	145	92
FM125 S10					169	110	225	166	281	222	337	278	161	102
FM125 S11					159	94	215	150	271	206	327	262	177	112
FM125 S12							205	134	261	190	317	246	193	122
FM140 S05	155	115	237	197	319	279							122	82
FM140 S06	139	91	220	172	302	254							147	99
FM140 S07	122	66	204	148	286	230	368	312					171	115
FM140 S08			188	123	269	205	351	287	433	369			196	132
FM140 S09			171	99	253	181	335	263	417	345	499	426	220	148
FM140 S10					237	156	318	238	400	320	482	402	245	164
FM140 S11					220	132	302	214	384	296	466	377	269	181
FM140 S12							285	189	367	271	449	353	294	197
FM160 S05	217	164	331	279	446	394							162	110
FM160 S06	195	132	309	246	424	361							195	132
FM160 S07	173	99	287	214	402	329	516	443					227	154
FM160 S08			265	182	380	296	494	411	609	525			260	176
FM160 S09			243	149	358	264	472	378	587	493	702	608	292	198
FM160 S10					336	231	450	346	565	460	680	575	324	220
FM160 S11					314	199	428	313	543	428	658	543	357	242
FM160 S12							406	281	521	396	636	510	389	264

PNEUMATIC ACTUATORS-R007-2019

Model	Air Supply Pressure (Unit: barg)												Spring Stroke	
	3		4		5		6		7		8			
	START	END	START	END	START	END	START	END	START	END	START	END	START	END
	0°	90°	0°	90°	0°	90°	0°	90°	0°	90°	0°	90°	90°	0°
FM190 S05	336	257	515	435	693	614							261	182
FM190 S06	300	205	478	383	657	562							313	218
FM190 S07	264	152	442	331	621	510	799	688					366	254
FM190 S08			406	279	584	457	763	636	942	815			418	291
FM190 S09			369	227	548	405	727	584	905	762	1084	941	470	327
FM190 S10					512	353	690	532	869	710	1048	889	522	363
FM190 S11					475	301	654	479	833	658	1011	837	574	400
FM190 S12							618	427	796	606	975	784	627	437
FM210 S05	478	364	727	613	977	863							359	245
FM210 S06	429	292	678	542	927	791							431	294
FM210 S07	380	220	629	470	878	719	1128	969					503	344
FM210 S08			580	398	829	647	1079	897	1328	1146			575	393
FM210 S09			531	326	780	576	1030	825	1279	1074	1528	1324	646	442
FM210 S10					731	504	980	753	1230	1002	1479	1252	718	491
FM210 S11					682	432	931	681	1181	931	1430	1180	790	540
FM210 S12							882	609	1132	859	1381	1108	862	589
FM240 S05	711	568	1098	954	1485	1341							554	410
FM240 S06	629	457	1016	844	1403	1230							665	493
FM240 S07	547	346	934	733	1321	1120	1707	1506					776	575
FM240 S08			852	622	1238	1009	1625	1396	2012	1782			886	657
FM240 S09			770	511	1156	898	1543	1285	1930	1672	2317	2058	997	739
FM240 S10					1074	787	1461	1174	1848	1561	2235	1948	1108	821
FM240 S11					992	676	1379	1063	1766	1450	2153	1837	1219	903
FM240 S12							1297	952	1684	1339	2070	1726	1330	985
FM270 S05	1018	791	1562	1335	2106	1879							786	560
FM270 S06	906	634	1450	1178	1994	1722							943	671
FM270 S07	794	477	1338	1021	1882	1565	2426	2109					1100	783
FM270 S08			1226	864	1770	1408	2314	1952	2858	2495			1258	895
FM270 S09			1114	707	1658	1250	2202	1794	2746	2338	3290	2882	1415	1007
FM270 S10					1546	1093	2090	1637	2634	2181	3178	2725	1572	1119
FM270 S11					1434	936	1978	1480	2522	2024	3066	2568	1729	1231
FM270 S12							1866	1323	2410	1867	2954	2411	1886	1343
FM300 S05	1338	997	2038	1697	2738	2397							1032	691
FM300 S06	1200	791	1900	1491	2600	2191							1238	829
FM300 S07	1062	585	1762	1285	2461	1984	3161	2684					1445	968
FM300 S08			1623	1078	2323	1778	3023	2478	3723	3178			1651	1106
FM300 S09			1485	872	2185	1572	2885	2271	3585	2971	4284	3671	1857	1244
FM300 S10					2047	1365	2747	2065	3446	2765	4146	3465	2064	1382
FM300 S11					1909	1159	2608	1859	3308	2558	4008	3258	2270	1520
FM300 S12							2470	1652	3170	2352	3870	3052	2477	1659
FM350 S05	2018	1536	3056	2575	4095	3613							1475	994
FM350 S06	1819	1241	2857	2280	3896	3318							1771	1193
FM350 S07	1620	946	2658	1985	3697	3023	4735	4062					2066	1392
FM350 S08			2459	1690	3498	2728	4537	3767	5575	4805			2361	1591
FM350 S09			2261	1395	3299	2433	4338	3472	5376	4510	6415	5549	2656	1790
FM350 S10			2062	1099	3100	2138	4139	3177	5177	4215	6216	5254	2951	1989
FM350 S11			1863	804	2901	1843	3940	2881	4979	3920	6017	4959	3246	2187
FM350 S12					2703	1548	3741	2586	4780	3625	5818	4664	3541	2386
FM400 S05	3013	2288	4596	3871	6179	5454							2301	1576
FM400 S06	2698	1828	4281	3411	5863	4993							2761	1891
FM400 S07	2383	1368	3966	2951	5548	4533	7131	6116					3221	2206
FM400 S08			3650	2490	5233	4073	6816	5656	8398	7238			3682	2522
FM400 S09			3335	2030	4918	3613	6500	5195	8083	6778	9665	8360	4142	2837
FM400 S10			3020	1570	4603	3153	6185	4735	7768	6318	9350	7900	4602	3152
FM400 S11			2705	1110	4287	2692	5870	4275	7452	5857	9035	7440	5062	3467
FM400 S12					3972	2232	5555	3815	7137	5397	8720	6980	5522	3782

PNEUMATIC-ACTUATORS-R007-2019

TECHNICAL DATA (IMPERIAL UNITS)

Model Type	FS032		FS050		FS065		FS075		FS085		FS095		FS110		FS125		FS140		FS160		FS190		FS210		FS240		FS270		FS300		FS350		FS400			
	D	S	D	S	D	S	D	S	D	S	D	S	D	S	D	S	D	S	D	S	D	S	D	S	D	S	D	S	D	S	D	S	D	S	D	S
Diameter (in)	1.26		1.97		2.56		2.95		3.35		3.74		4.33		4.92		5.51		6.30		7.48		8.27		9.45		10.63		11.81		13.78		15.75			
Air Volume Opening (in ³)	1.83		5.49		11.59		018.3		26.84		53.68		50.63		86.01		107.4		174		290		403		695		964		1164		1687		2611			
Air Volume Closing (in ³)	2.44		9.15		19.52		30.5		40.26		71.37		77.47		129.9		165.9		249		439		628		921		1147		1722		2690		3785			
Opening Time (sec)	0.3	0.3	0.9	0.4	0.9	0.4	0.9	0.9	1.0	0.9	1.4	0.9	1.4	0.9	1.3	1.3	2.4	1.3	2.8	2.0	4.8	2.2	2.4	2.9	3.4	3.2	3.8	4.4	5.0	5.0	6.0	6.2	7.4	7.5	9.6	9.6
Closing Time (sec)	0.4	0.4	0.7	0.4	0.8	0.4	0.9	0.9	1.2	1.0	1.4	1.0	1.6	1.4	2.4	1.4	3.0	2.4	4.9	2.6	3.0	3.8	4.1	3.7	4.0	4.9	5.5	6.0	6.8	7.2	8.4	8.5	10.6	10.6		
Weight (lbs)	1.0	1.3	2.5	2.7	4.3	4.9	6.4	7.2	8.3	9.4	11.3	12.9	13.4	15.7	23.9	27.5	30.3	34.9	44.4	52.3	62.4	74.2	88.2	106.7	116.0	139.6	162.3	199.7	237.2	298.7	324	412.8	483.1	621.5		

TECHNICAL DATA (METRIC UNITS)

Model Type	FM032		FM050		FM065		FM075		FM085		FM095		FM110		FM125		FM140		FM160		FM190		FM210		FM240		FM270		FM300		FM350		FM400			
	D	S	D	S	D	S	D	S	D	S	D	S	D	S	D	S	D	S	D	S	D	S	D	S	D	S	D	S	D	S	D	S	D	S	D	S
Diameter (mm)	32		50		65		75		85		95		110		125		140		160		190		210		240		270		300		350		400			
Air Volume Opening (L)	0.03		0.09		0.19		0.3		0.44		0.88		0.83		1.41		1.76		2.85		4.75		6.6		11.4		15.8		19.1		27.7		42.8			
Air Volume Closing (L)	0.04		0.15		0.32		0.5		0.66		1.17		1.27		2.13		2.72		4.08		7.2		10		15.1		18.8		28.2		44.1		62.1			
Opening Time (sec)	0.3	0.3	0.9	0.4	0.9	0.4	0.9	0.9	1.0	0.9	1.4	0.9	1.4	0.9	1.3	1.3	2.4	1.3	2.8	2.0	4.8	2.2	2.4	2.9	3.4	3.2	3.8	4.4	5.0	5.0	6.0	6.2	7.4	7.5	9.6	9.6
Closing Time (sec)	0.4	0.4	0.7	0.4	0.8	0.4	0.9	0.9	1.2	1.0	1.4	1.0	1.6	1.4	2.4	1.4	3.0	2.4	4.9	2.6	3.0	3.8	4.1	3.7	4.0	4.9	5.5	6.0	6.8	7.2	8.4	8.5	10.6	10.6		
Weight (kg)	0.47	0.59	1.13	1.25	1.97	2.21	2.93	3.29	3.78	4.26	5.14	5.86	6.09	7.17	10.9	12.5	13.8	15.9	20.2	23.8	28.4	33.8	40	48.4	52.6	63.3	73.6	90.6	108	136	147	188	220	283		

- For models FS032-160 & (FM032-160):
 - Room temperature
 - Actuator stroke 90°
 - Solenoid valve with orifice of 0.1/6" (4 mm) and a flow capacity of Qn106G/min (Qn400L/min)
 - Inside pipe diameter 1/4" (6 mm)
 - Medium: clean air
 - Air supply pressure 80psig (5.5) barg
 - Actuator without external resistance load

- For models FS190-400 & (FM190-400):
 - Room temperature
 - Actuator stroke 90°
 - Solenoid valve with orifice of 1/2" (12 mm) and a flow capacity of Qn1347G/min (Qn5100L/min)
 - Inside pipe diameter 5/16" (8 mm)
 - Medium: clean air
 - Air supply pressure 80psig (5.5) barg
 - Actuator without external resistance load

NOTE: Field applications, where one or more of the parameters above differ from the test conditions, may result in a stroke time difference

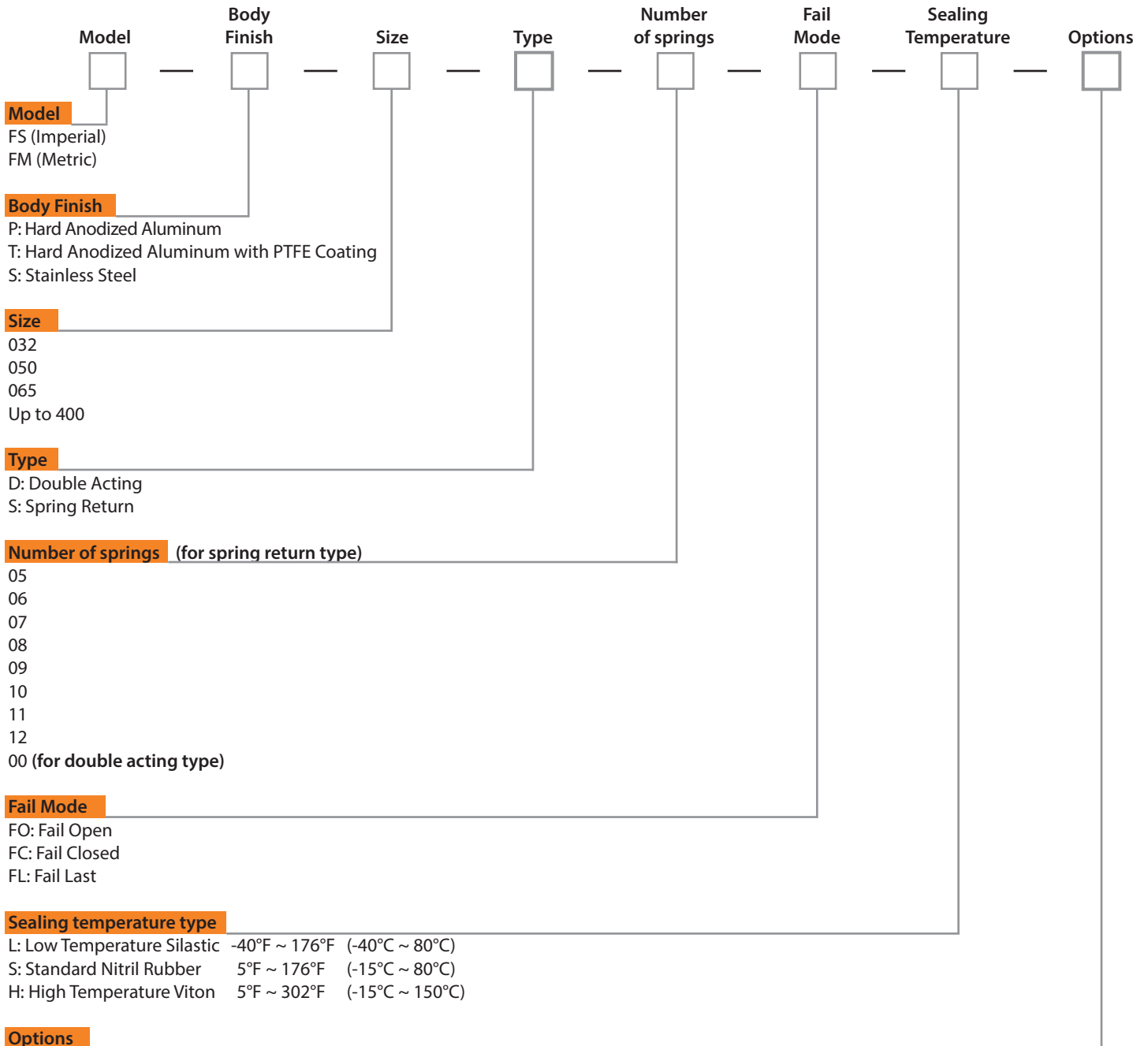

NOTES:

1. The standard rotation of double acting and spring return is clockwise to close (for double acting when port 4 is pressurized).
2. The standard operating temperature of seal is 5°F ~ 176°F (-15°C to 80°C), for high or low temperature applications alternate materials may be used.
3. For all technical parameters of the product please refer to this catalog. Customization for specific applications is available upon request.

MODEL SELECTION EXAMPLE

Example1: FSP095D00FLL

Description: Imperial Actuator, with Hard Anodized Aluminum body, Size 095, Double acting type, Fail Last, with a Low Temperature Sealing.

Example2: FMP095S06FCS

Description: Metric Actuator, with Hard Anodized Aluminum body, Size 095, Spring Return type, with 06 Springs, Fail Closed mode, with Standard Temperature Sealing.

TERMS & CONDITIONS



CONTROLLING PROVISIONS

These terms and conditions shall control with respect to any purchase order or sale of FluoroSeal Inc.'s products. No waiver, alteration or modification of these terms and conditions whether on Buyer's purchase order or otherwise, shall be valid unless the waiver, alteration or modification is specifically accepted in writing and signed by an authorized representative of FluoroSeal Inc.

DELIVERY FluoroSeal Inc. will make every effort to complete delivery of products as indicated on its acceptance of an order, but FluoroSeal Inc. assumes no responsibility or liability, and will accept no back charge, for loss or damage due to delay or inability to deliver caused by acts of God, war, labor difficulties, accident, delays of carriers, by contractors or suppliers, inability to obtain materials, shortages of fuel and energy, or any other causes of any kind whatever beyond the control of FluoroSeal Inc. FluoroSeal Inc. may terminate any contract of sale of its products without liability of any nature, by written notice to Buyer, in the event that the delay in delivery or performance resulting from any of the aforesaid causes shall continue for a period of sixty (60) days. Under no circumstances shall FluoroSeal Inc. be liable for any special or consequential damages or for loss, damage, or expense (whether or not based on negligence) directly or indirectly arising from delays or failure to give notice of delay.

WARRANTY FluoroSeal Inc. warrants for one year from the date of shipment of its manufactured products to the extent that FluoroSeal Inc. will replace those having defects in material or workmanship when used for the purpose and in the manner which FluoroSeal Inc. recommends. If FluoroSeal Inc.'s examination shall disclose to its satisfaction that the products are defective, and an adjustment is required, the amount of such adjustment shall not exceed the net sale price of the defective product(s) only and no allowance will be made for labor or expense for repairing or replacing defective products or workmanship or damage resulting from the same. FluoroSeal Inc. warrants the products which it sells of other manufacturers to the extent of the warranties of their respective makers. Where engineering design or fabrication work is supplied, Buyer's acceptance of FluoroSeal Inc.'s design or of delivery of work shall relieve FluoroSeal Inc. of all further obligation, other than expressed in FluoroSeal Inc.'s product warranty.

THIS IS FLUOROSEAL INC.'S SOLE WARRANTY. FLUOROSEAL INC. MAKES NO OTHER WARRANTY OF ANY KIND, EXPRESSED OR IMPLIED, AND ALL IMPLIED WARRANTIES OF MERCHANTABILITY AND FITNESS FOR A PARTICULAR PURPOSE WHICH EXCEED THE AFORE STATED OBLIGATION ARE HEREBY DISCLAIMED BY FLUOROSEAL INC. AND EXCLUDED FROM THIS WARRANTY.

FluoroSeal Inc. neither assumes, nor authorizes any person to assume for it, any other obligation in connection with the sale of its engineering designs or products. This warranty shall not apply to any products or parts of products which (a) have been repaired or altered outside of FluoroSeal Inc.'s factory, in any manner; (b) have been subjected to misuse, negligence or accidents; (c) have been used in a manner contrary to FluoroSeal Inc.'s instructions or recommendations. FluoroSeal Inc. shall not be responsible for design errors due to inaccurate or incomplete information supplied by Buyer or its representatives.

LIABILITY FluoroSeal Inc. will not be liable for any loss, damage, cost of repairs, incidental or consequential damages of any kind, whether based upon warranty (except for the obligation accepted by FluoroSeal Inc. under "Warranty" above), contract or negligence, arising in connection with the design, manufacture, sale, use or repair of the products or of

the engineering designs supplied to Buyer. Any litigation will be interpreted in accordance with the laws of the Province of Québec, Canada and any suit, action or proceeding relating to these terms and conditions may be instituted in any competent court sitting in the district of Montréal, Québec, Canada.

RETURNS FluoroSeal Inc. cannot accept return of any product(s) unless its written permission has been first obtained, in which case same will be credited subject to the following: (a) all material returned must, on its arrival at FluoroSeal Inc.'s plant, be found to be in first-class condition; if not, cost of putting in saleable condition will be deducted from credit memoranda; (b) a restocking charge will apply based on the nature of the product returned, and will be deducted from all credit memoranda issued for material returned; (c) transportation charges, if not prepaid, will be deducted from credit memoranda.

SHIPMENTS All products sent out will be carefully examined, counted and packed. The cost of any special packing or special handling caused by Buyer's requirements or requests shall be added to the amount of the order. No claim for shortages will be allowed unless made in writing within ten (10) days of receipt of a shipment. Claims for products damaged or lost in transit should be made to the carrier, as FluoroSeal Inc.'s responsibility ceases, and title passes, on delivery to the carrier.

SPECIAL PRODUCTS Orders covering special or non-standard products are not subject to cancellation except on such terms as FluoroSeal Inc. may specify on application.

PRICES AND DESIGNS Prices and designs are subject to change without notice. All prices are F.O.B. Point of Shipment, unless otherwise stated.

TAXES The amount of any sales, excise or other taxes, if any, applicable to the products, shall be added to the purchase price and shall be paid by Buyer unless Buyer provides FluoroSeal Inc. with an exemption certificate acceptable to the taxing authorities.

NUCLEAR PLANTS Where the products, engineering design or fabrication is for nuclear plant applications, Buyer agrees (a) to take all necessary steps to add FluoroSeal Inc. as an insured under the American Nuclear Insurers (ANI) pool and under the Mutual Atomic Energy Reinsurance Pool (MAERP) for property damage and liability insurance and if necessary steps could have been taken, but are not taken, Buyer shall hold FluoroSeal Inc. harmless against all such losses which could have been thus covered; (b) Buyer agrees to hold FluoroSeal Inc. harmless with respect to any personal injury or death, property damage or any other loss in a nuclear incident which is caused directly or indirectly by defective design, material, or workmanship, furnished by FluoroSeal Inc. and which is covered by insurance maintained by Buyer (or which could be so covered but with respect to which Buyer has elected to self-insure), and further agrees to waive subrogation by its carriers of such insurance against FluoroSeal Inc.; (c) as to nuclear hazards for which Buyer cannot obtain insurance coverage, the liability of FluoroSeal Inc. for any personal injury or death, property damage or any other loss directly caused by defective design, material, or workmanship furnished by FluoroSeal Inc. shall not exceed the value of the material furnished by FluoroSeal Inc. at the time of the loss occurrence.

MINIMUM INVOICE \$250 plus shipping.

TERMS Cash, net 30 days unless otherwise specified.

Most recent terms and conditions are available in the Downloads section of our website.

