

FluoroSeal



SLEEVED PLUG VALVES

NON-LUBRICATED PLUG VALVES

FluoroSeal®, Non-Lubricated, Sleeved Plug Valves incorporate state-of-the-art PTFE fluorocarbon seat design. With little required maintenance and trouble-free operation, a high integrity bubble-tight seal is provided both in-line and to atmosphere. The engineered design features contributing to the superiority of our product are described as a function of their specific purpose to ensure a trouble-free extended life.

LEAK-FREE PERFORMANCE

PTFE fluorocarbon, utilized in the FluoroSeal® sleeve and top seal components, is universally resistant to corrosive media, being inert to all but a few rarely encountered chemicals. It is a thermoplastic that can be used at a continuous service temperature of 400°F (204°C) and much higher temperatures can be satisfactorily sustained for shorter periods. Having a very low friction coefficient it is self-lubricating, negating the need for any other form of lubrication. Since PTFE is susceptible to deformation or cold flow as it is put under load, and as it becomes more pliable at elevated temperatures, precaution is taken to control this activity for the valve's intended purpose.

The FluoroSeal® internal body configuration has been designed to totally contain all the edges of the PTFE sleeve at the top, bottom, and around the entire port opening adjacent to the waterway. Any tendency of the sleeve to grow is accommodated by relief recesses designed for this purpose and positioned at 90 degrees to the body port openings. The port-defining metal lips protect the PTFE sleeve from erosion and any possibility of sleeve rotation within the body.

The waterway in the body has been designed with a contour providing a flow path that assures minimum flow turbulence characteristics. The critical sealing areas around the top and bottom of the sleeve and around the body port openings are maintained by means of an adjustable tapered plug compressing the PTFE sleeve over raised ribs.

The PTFE top seal components are similarly contained and protected from damage. A counter bore is provided at the top of the metal body to encapsulate the outside diameter of the formed PTFE diaphragm in conjunction with the formed metal diaphragm and to protect it from rupturing by regulating the amount of compression at this point.

The inside diameter of the formed PTFE diaphragm, adjacent to the plug stem, is also contained by means of a unique lip design of the formed metal diaphragm preventing extrusion and maintaining the stem seal throughout variable service conditions. This uniquely formed metal diaphragm also provides a positive electrical ground between the plug and body, eliminating the need for an extra component to fulfill this function as is the case for other valve manufacturers' designs.



ANSI/ASME Class 600 Lbs FluoroSeal® Plug Valve

PLUG-SLEEVED-R003-2025

DESIGN FEATURES



EFFORTLESS EFFICIENCY

As a standard, three point external adjusting bolts in the cover assure equilibrium to the compression of the stem and in-line seals by imparting a balanced force through a metal thrust washer located under the cover above the formed metal diaphragm. This mechanism provides a multiple seal to atmosphere and a double (downstream & upstream) bidirectional in-line seal.

Independent wrench stops are cast on the cover to limit the stroke at the open and close positions without endangering the integrity of the seal adjustment as in other manufacturers' designs. Parallel flats are machined on the sides of the plug stem providing positive indication of the direction of flow at all times, independent of other position indicators.

Offered as an option on all ANSI/ASME FluoroSeal® valves, and standard on all DIN valves up to DN 150, is the EZ-SEAL® (patented) Top Seal and Adjustment System. Featuring a single point adjustment it eliminates the possibility of plug side loading. The EZ-SEAL® (patented) also introduces a new industry standard by the incorporation of a Min / Max gauge on the cover, giving a visual indication of the remaining service life of a valve and easing the process of maintenance planning.

PLEDGE OF QUALITY

All major pressure bearing and/or boundary components (body, plug and cover) of FluoroSeal® valves are fully traceable to mill test certificates ensuring material authenticity. Quality levels are maintained through continuous inspection and manufacturing surveillance of these and all other components. A concerted effort is made to conform to all regulatory authority requirements where and when invoked, in keeping with FluoroSeal Inc.'s pledge of quality first. FluoroSeal® Plug Valves comply with the following standards:

API 598	API 599	ASME B16.5
ASME B16.10	ASME B16.25	ASME B16.34
ASME B16.42	DIN EN 558-1	MSS SP-61
DIN EN 1092-1	DIN EN 12266	MSS SP-55
ISO/FDI 10497		

AT A GLANCE

- Bidirectional flow
- Quarter-turn operation
- Non-lubricated
- Self-cleaning on each operation
- 2-way and multiport configurations
- Special service and jacketed designs available
- All casting components traceable to mill test certificates

- Investment cast on all materials for sizes 1/2" – 12" (ANSI/ASME Class 150 lbs)
- Investment cast on all materials for sizes 1/2" – 6" (ANSI/ASME Class 300 lbs)
- Investment cast on all materials for sizes 1/2" – 6" (ANSI/ASME Class 600 lbs)
- Investment cast on all materials for sizes DN 15 – DN 150 (PN 16 – PN 40)
- Standard heavy-duty gears available on all FluoroSeal® valves

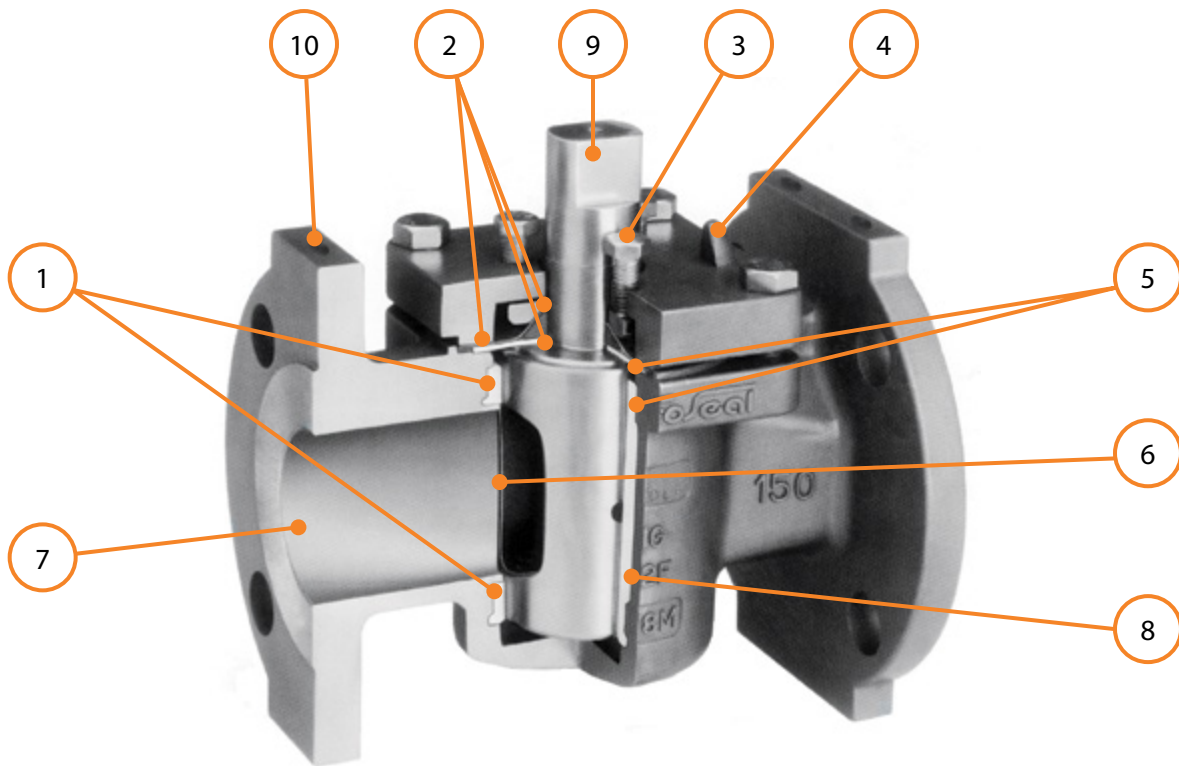

ANSI/ASME Class 150 Lbs FluoroSeal® Plug Valve Cut-Away

DESIGN FEATURES SUMMARY

1. Bidirectional in-line bubble-tight seal independent of line pressure
2. Multiple external bubble-tight seals independent of line pressure
3. Direct mechanical three-point adjustment independent of line pressure
4. Independent travel stops
5. Full encapsulation and retention of all leading edges of PTFE sleeve and top seal components
6. Full lip at port openings protects PTFE sleeve
7. Contoured waterway ensures minimum flow turbulence characteristic
8. No body cavities to entrap flow media
9. Positive flow direction indication
10. Drilled and tapped flange actuation-mounting pads independent of cover and top seal assembly. This feature is optional on lever-operated valves (1/2" thru 4") in HASTELLOY®, INCONEL®, Titanium, and Zirconium alloys.



ANSI/ASME Class 150 Lbs FluoroSeal® Plug Valve with Wrench

MATERIALS OF CONSTRUCTION

Body and Plug ¹	As Specified
Cover ²	Carbon Steel or 304 SS
Cover Bolts ²	Carbon Steel or 304 SS
Adjusting Bolts	304 SS
Thrust Washer	304 SS
Metal Diaphragm ³	304 SS, MONEL®
Delta Ring	PTFE Fluorocarbon
Diaphragm	PTFE Fluorocarbon
Sleeve ⁴	PTFE Fluorocarbon
Wrench Operator ⁵	Carbon Steel
Wrench Bolt ⁵	Steel
Gear Assembly	Heavy Duty Cast Carbon Steel Housing
Gear Adaptor ⁵	Hi-Strength Steel
Gear Mounting Bracket	304 SS
Mounting Bracket Bolts ⁵	Steel

1. See BODY & PLUGS MATERIAL TABLE for material selections.
2. Cover and bolt materials of standard valves will be supplied in accordance with the following table:

SPECIFIED BODY	COVER	ANSI/ASME COVER BOLT	DIN COVER BOLT
Ductile Iron	Carbon Steel	ASTM A193 Gr. B7	DIN EN 10269
Carbon Steel	Carbon Steel	ASTM A193 Gr. B7	DIN EN 10269
All Other Materials	CF8	ASTM A193 Gr. B8	DIN EN 10269

Covers can be delivered in the same material as body if specified at time of order.

3. MONEL® metal diaphragms will be supplied with valves having a MONEL® or nickel trim. All others will be supplied with 304 SS diaphragms.
4. Glass reinforced PTFE (RTFE), PFA Fluorocarbon, GF2P, Hi-Temp, and UHMWPE sleeves are available on special order.
5. 304 SS available on special order.

PLUG-SLEEVED-R003-2025

FluoroSeal



SLEEVED 2-WAY

SLEEVED PLUG VALVES — 2-WAY



2-WAY ANSI/ASME CLASS 150 LBS

Flanged Ends

Wrench or Enclosed Gear Operated

Actuators Optional on All Sizes

Dimensions to ANSI B16.5 & B16.10

E = Clearance required for resleeving measured from center line

EG = Enclosed gear operated

N = Number of holes

Two (2) top holes in flanges are tapped with UNC threads. See Hole-UNC column

¹ Six (6) top holes

* 2 1/2" valves are made from 3" casting, but flanges are machined to 2 1/2" dimensions

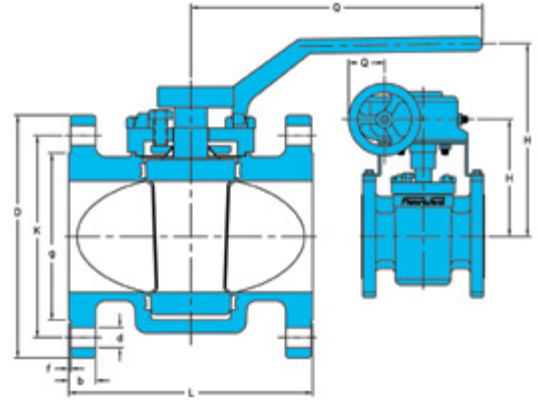

SIZE	L		H		D		K		g		b		f		d		Q		Weight		E		N	Hole-UNC
	in	mm	in	mm	in	mm	in	mm	in	mm	in	mm	in	mm	in	mm	kg	lbs	in	mm	#			
1/2"	4.25	108.00	3.38	86.00	3.50	88.90	2.38	60.50	1.38	35.00	0.37	9.50	0.06	1.52	0.63	16.00	8.00	203.00	2.3	5.0	6.38	162.10	4	-
3/4"	4.63	117.50	3.38	86.00	3.88	98.50	2.75	69.90	1.68	42.90	0.37	9.50	0.06	1.52	0.63	16.00	8.00	203.00	2.7	6.0	6.38	162.10	4	-
1"	5.00	127.00	4.50	114.00	4.25	108.00	3.13	79.50	2.00	50.80	0.44	11.20	0.06	1.52	0.63	16.00	9.00	229.00	3.6	8.0	8.50	215.90	4	-
1 1/2"	6.50	165.10	5.31	135.00	5.00	127.00	3.88	98.60	2.88	73.20	0.56	14.20	0.06	1.52	0.63	16.00	14.25	362.00	6.4	14.0	10.38	263.70	4	-
2"	7.00	177.80	6.25	159.00	6.00	152.40	4.75	120.70	3.63	92.00	0.63	16.00	0.06	1.52	0.75	19.00	16.50	419.00	10.5	23.0	12.25	311.20	4	-
*2 1/2"	8.00	203.20	6.56	167.00	7.50	190.50	5.50	139.70	4.13	104.60	0.75	19.00	0.06	1.52	0.75	19.00	16.50	419.00	16.4	36.0	12.63	320.80	4	-
3"	8.00	203.20	6.56	167.00	7.50	190.50	6.00	152.40	5.00	127.00	0.75	19.00	0.06	1.52	0.75	19.00	16.50	419.00	16.4	36.0	13.63	346.20	4	-
4"	9.00	228.60	7.63	194.00	9.00	228.60	7.50	190.50	6.19	157.20	0.94	23.90	0.06	1.52	0.75	19.00	23.63	600.00	26.8	59.0	16.25	412.80	8	-
4" EG	9.00	228.60	9.10	231.00	9.00	228.60	7.50	190.50	6.19	157.20	0.94	23.90	0.06	1.52	0.75	19.00	7.25	184.00	35.9	79.0	17.63	447.80	8	-
6" EG	10.50	266.70	10.80	274.00	11.00	279.40	9.50	241.30	8.50	215.90	1.00	25.40	0.06	1.52	0.88	22.40	7.25	184.00	55.5	122.0	21.75	552.50	8	-
8" EG	11.50	292.10	12.75	324.00	13.50	342.90	11.75	298.50	10.63	269.80	1.13	28.70	0.06	1.52	0.88	22.40	9.75	248.00	100.0	220.0	26.63	676.40	8	3/4"-10
10" EG	13.00	330.20	14.68	373.00	16.00	406.40	14.25	362.00	12.75	323.90	1.19	30.20	0.06	1.52	1.00	25.40	9.75	248.00	150.0	330.0	31.25	793.80	12	7/8"-9
12" EG	14.00	355.60	16.40	417.00	19.00	482.60	17.00	431.80	15.00	381.00	1.25	31.80	0.06	1.52	1.00	25.40	13.75	349.25	198.6	437.0	33.75	857.30	12	7/8"-9
14" EG	15.00	381.00	17.40	442.00	21.00	533.40	18.75	476.30	16.25	412.80	1.38	35.10	0.06	1.52	1.12	28.40	13.75	349.25	295.0	650.0	34.75	882.70	12	1"-8
16" EG	30.00	762.00	21.29	540.72	23.00	584.20	21.25	539.75	18.50	469.90	1.38	35.05	0.06	1.52	1.13	28.58	9.85	250.19	-	-	46.00	1168.40	16	1"-8
18" EG	34.00	863.60	21.29	540.84	25.00	635.00	22.75	577.85	21.00	533.40	1.50	38.10	0.06	1.52	1.25	31.75	9.85	250.19	-	-	46.00	1168.40	16	1 1/8"-8
20" EG	36.00	914.40	27.43	696.70	27.00	685.80	25.00	635.00	23.00	584.20	1.62	41.15	0.06	1.52	1.25	31.75	9.85	250.19	-	-	57.63	1463.80	20	1 1/8"-8 ¹
24" EG	42.00	1066.8	27.43	696.70	31.00	787.40	29.50	749.30	27.25	692.15	1.81	45.97	0.06	1.52	1.38	34.93	9.85	250.19	-	-	57.63	1463.80	20	1 1/4"-8

2-WAY ANSI/ASME CLASS 300 LBS

Flanged Ends

Wrench or Enclosed Gear Operated

Actuators Optional on All Sizes

Dimensions to ANSI B16.5 & B16.10

E = Clearance required for resleeving measured from center line

EG = Enclosed gear operated

N = Number of holes

Two (2) top holes in flanges are tapped with UNC threads. See Hole-UNC column

¹ Four (4) top holes

* 2 1/2" valves are made from 3" casting, but flanges are machined to 2 1/2" dimensions

SIZE	L		H		D		K		g		b		f		d		Q		Weight		E		N	Hole-UNC
	in	mm	in	mm	in	mm	in	mm	in	mm	in	mm	in	mm	in	mm	kg	lbs	in	mm	#			
1/2"	5.50	139.70	3.38	86.00	3.75	95.30	2.63	66.80	1.38	35.00	0.56	14.20	0.06	1.52	0.63	16.00	8.00	203.00	3.2	7.0	6.38	162.10	4	-
3/4"	6.00	152.40	3.38	86.00	4.63	117.60	3.25	82.60	1.69	42.70	0.63	16.00	0.06	1.52	0.75	19.00	8.00	203.00	4.1	9.0	6.38	162.10	4	-
1"	6.50	165.10	4.50	114.00	4.88	124.00	3.50	88.90	2.00	50.80	0.69	17.50	0.06	1.52	0.75	19.00	9.00	229.00	5.5	12.0	8.50	215.90	4	-
1 1/2"	7.50	190.50	5.31	135.00	6.13	155.70	4.50	114.30	2.88	73.20	0.81	20.60	0.06	1.52	0.88	22.40	14.25	362.00	9.5	21.0	10.38	263.70	4	-
2"	8.50	215.90	6.25	159.00	6.50	165.10	5.00	127.00	3.63	92.00	0.88	22.40	0.06	1.52	0.75	19.00	16.50	419.00	13.2	29.0	12.25	311.20	8	-
*2 1/2"	11.13	282.70	6.56	167.00	8.25	209.60	5.88	149.40	4.13	104.60	1.13	28.70	0.06	1.52	0.88	22.40	16.50	419.00	21.8	48.0	12.63	320.80	8	-
3"	11.13	282.70	6.56	167.00	8.25	209.60	6.63	168.40	5.00	127.00	1.13	28.70	0.06	1.52	0.88	22.40	16.50	419.00	21.8	48.0	13.63	346.20	8	-
4"	12.00	304.80	7.63	194.00	10.00	254.00	7.88	200.20	6.19	157.20	1.25	31.80	0.06	1.52	0.88	22.40	23.63	600.00	42.0	92.0	16.25	412.80	8	-
4" EG	12.00	304.80	9.10	231.00	10.00	254.00	7.88	200.20	6.19	157.20	1.25	31.80	0.06	1.52	0.88	22.40	7.25	184.00	54.0	119.0	17.63	447.80	8	-
6" EG	15.88	403.40	10.80	274.00	12.50	317.50	10.63	270.00	8.50	215.90	1.44	36.60	0.06	1.52	0.88	22.40	7.25	184.00	91.4	201.0	21.75	552.50	12	-
8" EG	16.50	419.10	12.75	324.00	15.00	381.00	13.00	330.20	10.63	269.80	1.63	41.40	0.06	1.52	1.00	25.40	9.75	248.00	141.4	311.0	26.63	676.40	12	7/8"-9
10" EG	18.00	457.20	14.68	373.00	17.50	444.50	15.25	387.40	12.75	323.90	1.88	47.80	0.06	1.52	1.13	28.70	9.75	248.00	210.9	464.0	31.25	793.80	16	1"-8
12" EG	19.75	501.70	16.40	417.00	20.50	520.70	17.75	450.90	15.00	381.00	2.00	50.80	0.06	1.52	1.25	31.80	13.75	349.25	279.0	614.0	33.75	857.30	16	1 1/8"-8
14" EG	30.00	762.00	17.40	442.00	23.00	584.20	20.25	514.40	16.25	412.80	2.12	53.80	0.06	1.52	1.25	31.80	13.75	349.25	363.0	800.0	34.75	882.70	20	-
16" EG	33.00	838.20	21.29	540.72	25.50	647.70	22.50	571.50	18.50	469.90	2.19	55.63	0.06	1.52	1.38	34.93	9.85	698.50	-	-	46.00	1168.40	20	1 1/4"-8
18" EG	36.00	914.40	21.29	540.84	28.00	711.20	24.75	628.65	21.00	533.40	2.31	58.67	0.06	1.52	1.38	34.93	9.85	698.50	-	-	46.00	1168.40	24	-
20" EG	39.00	990.60	27.43	696.70	30.50	774.70	27.00	685.80	23.00	584.20	2.44	61.98	0.06	1.52	1.38	34.93	9.85	698.50	-	-	57.63	1463.80	24	1 1/4"-8 ¹
24" EG	45.00	1143.0	27.43	696.70	36.00	914.40	32.00	812.80	27.25	692.15	2.69	68.33	0.06	1.52	1.63	41.28	9.85	698.50	-	-	57.63	1463.80	24	1 1/2"-8

PLUG-SLEEVED-R003-2025

2-WAY ANSI/ASME CLASS 600 LBS

Flanged Ends

Wrench or Enclosed Gear Operated

Actuators Optional on All Sizes

E = Clearance required for resleeving measured from center line

EG = Enclosed gear operated

N = Number of holes

Two (2) top holes in flanges are tapped with UNC threads. See Hole-UNC column

* Available upon request

SIZE	L		H		D		K		g		b		f		d		Q		Weight		E		N	Hole-UNC
	in	mm	in	mm	in	mm	in	mm	in	mm	in	mm	in	mm	in	mm	in	mm	kg	lbs	in	mm	#	
1/2"	6.50	165.10	3.38	85.70	3.75	95.30	2.62	66.50	1.38	35.10	0.56	14.20	0.25	6.35	0.62	15.70	8.00	203.20	3.6	8.0	6.38	162.10	4	-
3/4"	7.50	190.50	3.38	85.90	4.62	117.30	3.25	82.60	1.69	42.90	0.62	15.70	0.25	6.35	0.75	19.10	8.00	203.20	5.0	11.0	6.38	162.10	4	-
1"	8.50	215.90	4.50	114.30	4.88	124.00	3.50	88.90	2.00	50.80	0.69	17.50	0.25	6.35	0.75	19.10	9.00	228.60	7.3	16.0	8.50	215.90	4	-
1 1/2"	9.50	241.30	5.31	134.90	6.12	155.40	4.50	114.30	2.88	73.20	0.88	22.40	0.25	6.35	0.88	22.40	14.25	362.00	12.3	27.0	10.38	263.70	4	-
2"	11.50	292.10	6.25	158.80	6.50	165.10	5.00	127.00	3.62	91.90	1.00	25.40	0.25	6.35	0.75	19.10	16.50	419.10	18.2	40.0	12.25	311.20	8	-
2 1/2"	14.00	355.60	6.56	166.60	7.50	190.50	5.88	149.40	4.12	104.60	1.12	28.40	0.25	6.35	0.88	22.40	16.50	419.10	38.6	85.0	12.63	320.80	8	-
3"	14.00	355.60	6.56	166.60	8.25	209.60	6.62	168.10	5.00	127.00	1.25	31.80	0.25	6.35	0.88	22.40	16.50	419.10	38.6	85.0	13.63	346.20	8	-
4"	17.00	431.80	7.53	191.10	10.75	273.10	8.50	215.90	6.19	157.20	1.50	38.10	0.25	6.35	1.00	25.40	23.63	600.20	68.2	150.0	16.25	412.80	8	-
4" EG	17.00	431.80	9.10	231.10	10.75	273.10	8.50	215.90	6.19	157.20	1.50	38.10	0.25	6.35	1.00	25.40	7.25	184.20	81.8	180.0	17.63	447.80	8	-
6" EG	22.00	558.80	10.80	274.30	14.00	355.60	11.50	292.10	8.50	215.90	1.88	47.80	0.25	6.35	1.12	28.40	7.25	184.20	152.3	335.0	21.75	552.50	12	-
8" EG	26.00	660.40	12.75	323.90	16.50	419.10	13.75	349.30	10.62	269.70	2.19	55.60	0.25	6.35	1.25	31.80	9.75	247.70	222.7	490.0	26.63	676.40	12	1 1/8"-8
10" EG*	31.00	787.40	14.68	372.90	20.00	508.00	17.00	431.80	12.75	323.90	2.50	63.50	0.25	6.35	1.38	35.10	9.75	247.70	-	-	31.25	793.80	16	1 1/4"-8
12" EG*	33.00	838.20	16.40	416.60	22.00	558.80	19.25	489.00	15.00	381.00	2.62	66.50	0.25	6.35	1.38	35.10	13.75	349.25	-	-	33.75	857.30	20	1 1/4"-8
14" EG*	35.00	889.00	15.66	397.84	23.75	603.25	20.75	527.05	16.25	412.75	2.75	69.85	0.25	6.35	1.50	38.10	13.75	349.25	-	-	34.75	882.70	20	1 3/8"-8
16" EG*	39.00	990.60	21.29	540.72	27.00	685.80	23.75	603.25	18.50	469.90	3.00	76.20	0.25	6.35	1.63	41.28	9.85	250.19	-	-	46.00	1168.40	20	1 1/2"-8
18" EG*	43.00	1092.20	21.29	540.84	29.50	749.30	25.75	654.10	21.00	533.40	3.25	82.60	0.25	6.35	1.75	44.50	9.85	250.19	-	-	46.00	1168.40	20	1 5/8"-8

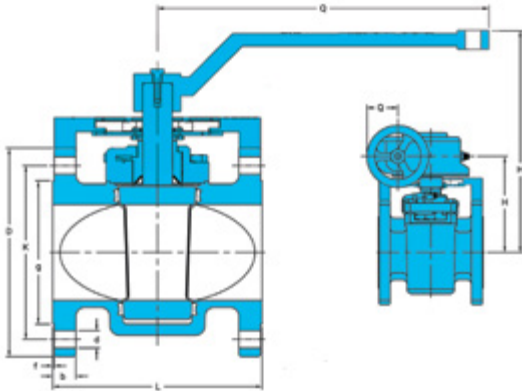

2-WAY DIN PN 16 & PN 40

Flanged Ends

Wrench or Enclosed Gear Operated

Actuators Optional on All Sizes

Dimensions to DIN EN 1092-1 & DIN EN 558-1

Enclosed gear optional on DN 100, and standard on DN 125 and DN 150

E = Clearance required for resleeving measured from center line

N = Number of holes

Two (2) top holes in flanges are tapped with metric threads. See Bolt Size column

*According to DIN EN 1092-2 (Cast Iron Flanges) and DIN prEN 1092-3 (Copper Alloy Flanges), the flanges in this DN and PN may be supplied with four (4) holes. Where steel flanges are required with four (4) holes, these may be supplied by agreement between manufacturer and purchaser.

SIZE	PN	L	H	D	K	g	b	f	d	Q	Weight	E	N	Bolt Size
		mm	mm	mm	mm	mm	mm	mm	mm	mm	kg	mm	#	
DN 15	16 & 40	130.00	145.00	95.00	65.00	45.00	16.00	2.00	14.00	210.00	-	131.00	4	M12
DN 20	16 & 40	150.00	145.00	105.00	75.00	58.00	18.00	2.00	14.00	210.00	-	131.00	4	M12
DN 25	16 & 40	160.00	145.00	115.00	85.00	68.00	18.00	2.00	14.00	210.00	-	131.00	4	M12
DN 32	16 & 40	180.00	176.00	140.00	100.00	78.00	18.00	2.00	18.00	262.50	-	161.00	4	M16
DN 40	16 & 40	200.00	176.00	150.00	110.00	88.00	18.00	2.00	18.00	262.50	-	161.00	4	M16
DN 50	16	230.00	195.00	165.00	125.00	102.00	18.00	2.00	18.00	419.10	-	189.00	4	M16
	40	230.00	195.00	165.00	125.00	102.00	20.00	2.00	18.00	419.10	-	189.00	4	M16
DN 65	16	290.00	173.00	185.00	145.00	122.00	18.00	2.00	18.00	419.10	-	217.00	8*	M16
	40	290.00	173.00	185.00	145.00	122.00	22.00	2.00	18.00	419.10	-	217.00	8	M16
DN 80	16	310.00	173.00	200.00	160.00	138.00	20.00	2.00	18.00	419.10	-	217.00	8	M16
	40	310.00	173.00	200.00	160.00	138.00	24.00	2.00	18.00	419.10	-	217.00	8	M16
DN 100	16	350.00	200.00	220.00	180.00	158.00	20.00	2.00	18.00	618.00	-	270.00	8	M16
	40	350.00	200.00	235.00	190.00	162.00	24.00	2.00	22.00	618.00	-	270.00	8	M20
DN 125	16	325.00	303.00	250.00	210.00	188.00	22.00	2.00	18.00	184.20	-	370.00	8	M16
	40	325.00	303.00	270.00	220.00	188.00	26.00	2.00	26.00	184.20	-	370.00	8	M24
DN 150	16	350.00	290.00	285.00	240.00	212.00	22.00	2.00	22.00	184.20	-	370.00	8	M20
	40	350.00	290.00	300.00	250.00	218.00	28.00	2.00	26.00	184.20	-	370.00	8	M24

PLUG-SLEEVED-R003-2025

SLEEVED PLUG VALVES — 2-WAY



2-WAY ANSI/ASME CLASS 150/300/600 LBS

Screwed Ends

Wrench Operated

Actuators Optional on All Sizes

Dimensions to ANSI B16.11

E = Clearance required for resleeving measured from center line

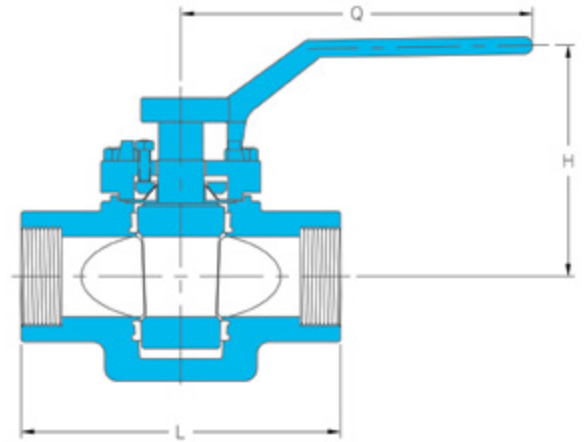

SIZE	L		H		Q		Weight		E	
	in	mm	in	mm	in	mm	kg	lbs	in	mm
1/2"	3.93	100.00	3.38	85.90	8.00	203.00	2.0	4.4	6.38	162.10
3/4"	3.93	100.00	3.38	85.50	8.00	203.00	2.0	4.4	6.38	162.10
1"	5.50	140.00	4.50	114.00	9.00	229.00	3.0	6.6	8.50	215.90
1 1/2"	6.30	160.00	5.31	135.00	14.25	362.00	6.0	13.2	10.38	263.70
2"	7.87	200.00	6.25	159.00	16.50	419.00	10.0	22.0	12.25	311.20
2 1/2"	7.87	200.00	6.56	167.00	16.50	419.00	11.0	24.0	12.63	320.80

2-WAY ANSI/ASME CLASS 150/300/600 LBS

Socket Weld Ends

Wrench Operated

Actuators Optional on All Sizes

Dimensions to ANSI B16.11

E = Clearance required for resleeving measured from center line

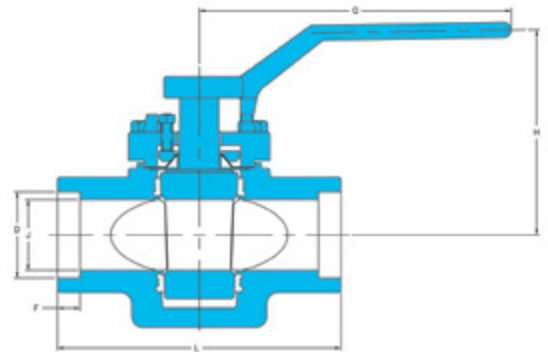

SIZE	L		H		D		J		F		Q		Weight		E	
	in	mm	in	mm	in	mm	in	mm	in	mm	in	mm	kg	lbs	in	mm
1/2"	3.93	100.00	3.38	85.90	0.85	21.70	0.55	14.00	0.37	9.50	8.00	203.00	2.0	4.4	6.38	162.10
3/4"	3.93	100.00	3.38	85.50	1.07	27.20	0.75	19.00	0.50	12.70	8.00	203.00	2.0	4.4	6.38	162.10
1"	5.50	140.00	4.50	114.00	1.34	34.00	0.98	25.00	0.50	12.70	9.00	229.00	3.0	6.6	8.50	215.90
1 1/2"	6.30	160.00	5.31	135.00	1.92	48.80	1.50	38.00	0.50	12.70	14.25	362.00	6.0	13.2	10.38	263.70
2"	7.87	200.00	6.25	159.00	2.40	61.00	1.97	50.00	0.66	16.70	16.50	419.00	10.0	22.0	12.25	311.20
2 1/2"	7.87	200.00	6.56	167.00	2.91	73.91	2.41	61.21	7.88	200.15	16.50	419.00	11.0	24.0	12.63	320.80

PLUG-SLEEVED-R003-2025

FluoroSeal



SPECIAL SERVICE

SLEEVED PLUG VALVES — SPECIAL SERVICE



SPECIAL SERVICE FLUOROSEAL® PLUG VALVES

Whether you are looking for a valve to suit a specific application, or want to customize a standard FluoroSeal® Plug Valve, you have come to the right place. Our special service valves provide you with both an array of turn-key solutions and the ability to fully match your application needs.

CAGED CONTROL PLUG VALVES

The Caged Control Valve is ideal for abrasive applications with high solids concentrations and is commonly used in both throttling and on/off applications. Caged valves have been used successfully in many critical applications in the Mining, Pulp & Paper, and Chemical Processing industries.

The design of the Caged Control Valve provides maximum protection to the polymer sealing surfaces in the plug valves. The key to the caged design is that the PTFE sleeve in the valve is never directly exposed to the process flow. This allows the sleeve to maintain its sealing integrity in abrasive applications.

The design of the Caged Control Valve allows the plug to rotate freely around a fixed cage within the body. The cage is stationary in the body while the plug rotates, thus allowing the sealing area of the plug to be in direct contact with the sleeve to provide bubble-tight shutoff. The cage stays in position protecting the polymer sleeve from erosion/abrasion while the plug is in any intermediate position such as when the valve is moving from the open to the closed position or when the valve is throttling.

The cage has upper and lower graphite filled RTFE bearings that prevent galling between the plug and cage. A keyway keeps the cage from rotating in the body. This allows free movement of the plug around the cage.

The Caged Control Valve still allows for in-line adjustment for through valve leakage just as a standard plug valve does since the plug and the cage are independent of each other.

The cage and plug in the Caged Control Valve are generally made from CD4MCu material, an abrasion resistant alloy with the corrosion resistance of 316 SS. Caged Control Valves are available in any material, from carbon steel and stainless steel to any of the more exotic alloys.



PLUG-SLEEVED-R003-2025

UREA SERVICE — A CAGED CONTROL SHOWCASE

An excellent example of the efficiency designed into a Cage Control Valve is its use in urea service. In combination with a side flush option as demonstrated in Double Block and Bleed Valves, the FluoroSeal® Cage Control Plug Valve can withstand frequent pressure drops and urea crystallization present in the fabrication of this chemical reactant.

Inherently corrosive and erosive, urea service requires a valve designed to protect its main seals from the attack of the urea flow and possible particulates. Not only does the Caged Control Valve achieve this, it also effectively prevents the valve from clogging and sticking.

SPECIAL CLEANING PLUG VALVES

FluoroSeal® Special Cleaning Plug Valves can be prepared for a variety of demanding service applications, such as hydrogen, isocyanate, oxygen, phosgene and chlorine.

In the case of chlorine, FluoroSeal® Chlorine Service Valves are provided with a vented plug to relieve pressure to the upstream side. This modification results in a uni-directional valve which is indicated on the valve with a flow direction arrow.

FluoroSeal® Sleeved Plug Valves are manufactured in accordance with the recommendations of the Chlorine Institute Pamphlet 6 and provide superior performance in this demanding application. All FluoroSeal® Chlorine Valves are made from thoroughly cleaned and dried components under controlled conditions and this control is maintained throughout parts preparation, assembly, testing and special protective packaging. Other customer requirements can be incorporated upon request, provided that they conform to the specifications of Pamphlet 6.

H₂S SERVICE — NACE / MR0175 / ISO 15156-1/2/3 COMPLIANCE

FluoroSeal® Plug Valves are available for use in H₂S-containing environments in conformance with the material requirements of NACE / MR0175 / ISO 15156-1/2/3. Available upon client request and approval, all FluoroSeal® plug valves can be manufactured to incorporate NACE / ISO pre-qualified materials identified in NACE MR0175 / ISO 15156-2/3. It is FluoroSeal Inc. policy that, where environmental or other conditions require, FluoroSeal Inc. will work with the client to select materials based on field experience or laboratory testing in accordance with the requirements/procedures of NACE MR0175 / ISO 15156-2/3.

PLUG-SLEEVED-R003-2025



Chlorine Service Packaging Caution Tags

SLEEVED PLUG VALVES — SPECIAL SERVICE



DOUBLE BLOCK & BLEED AND SAMPLING PLUG VALVES

Because of the double port seals in both directions and the sealed isolation of the chamber below the plug and the areas around the plug, 90° to the port openings, a drainage connection into the plug cavity may be drilled and tapped through the body from either side or the bottom.

A 1/2" (12.7 mm) drain connection is standard, but other sizes can also be provided. Specify connection size; length as indicated on the drawing and whether the bleed valve is required. A FluoroSeal® Fig. R152/302SE is ideally suited as the bleed valve.

ANSI/ASME

Bleed valve diameter 1/2" available in block valve size 2", 2 1/2", 3", 4"

Bleed valve diameter 3/4" available in block valve size 6", 8"

Bleed valve diameter 1" available in block valve size 10", 12", 14", 16", 18", 24"

DIN

Bleed valve diameter DN 15 available in block valve size DN 50, DN 65, DN 80, DN 100

Bleed valve diameter DN 20 available in block valve size DN 150



ANSI/ASME FluoroSeal® Double Block and Bleed Plug Valve with Gear

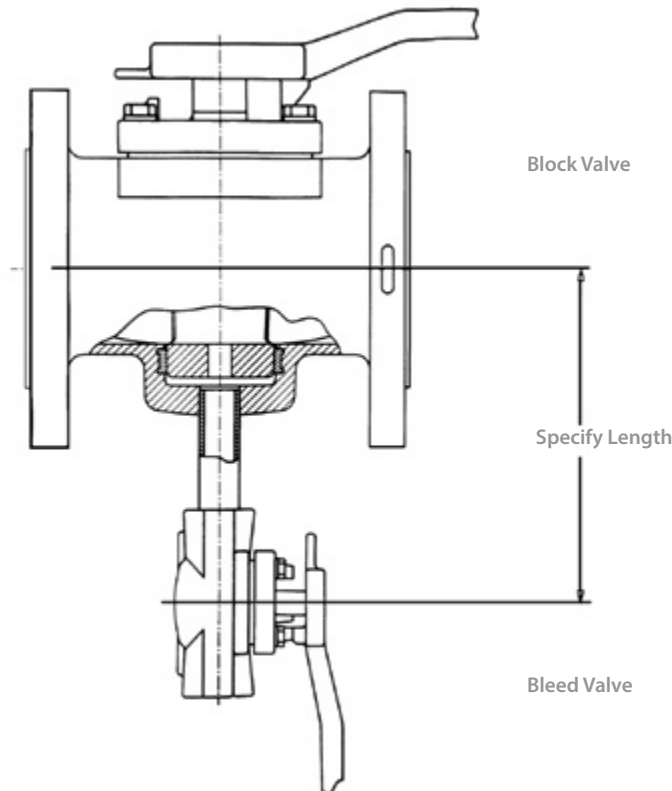

PLUG-SLEEVED-R003-2025

FIRE SAFE SLEEVED PLUG VALVES



FluoroSeal® Fire Safe Plug Valve

FluoroSeal® Sleeved Plug Valves with the Fire Safe top seal have been tested and certified by an independent laboratory to the requirements of API 607, latest edition (ISO 10497-5) for external leakage.

The FluoroSeal® Fire Safe design utilizes a PTFE sleeve and PTFE diaphragm as the external sealing components under normal conditions. Should these components be destroyed by fire, external leakage is prevented by:

1. A secondary flexible graphite seal ring encapsulated and compressed between the metal diaphragm and the machined counterbore in the valve body
2. A flexible graphite delta ring encapsulated and compressed between the unique shaped metal diaphragm and the machined plug stem

FluoroSeal® Fire Safe Valves also utilize a vented plug designed to relieve pressure buildup resulting from expansion of the service media within the plug, due to elevated temperatures caused by fire. The pressure is relieved to the upstream side, providing a preferred flow direction indicated by an arrow on the valve cover.

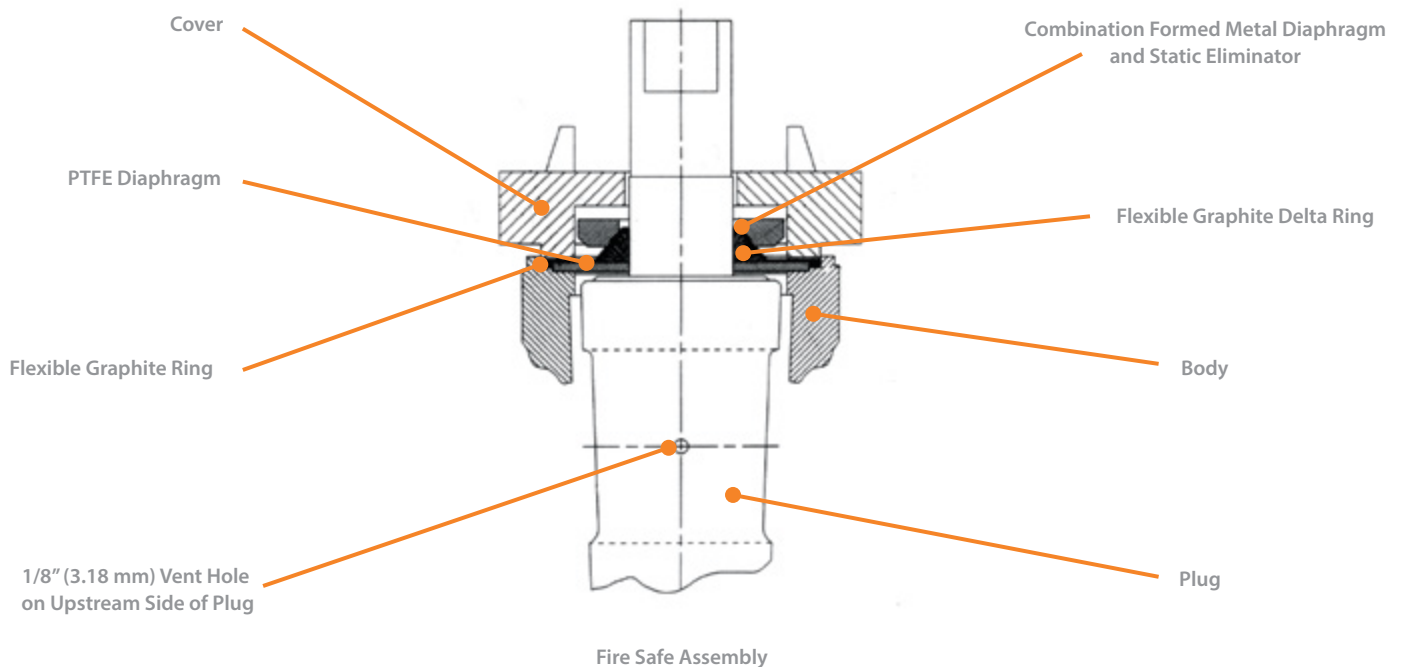

PLUG-SLEEVED-R003-2025

FluoroSeal



OPTIONS

PLUG VALVES — OPTIONS

FluoroSeal

EZ-SEAL® TOP SEAL & ADJUSTMENT SYSTEM

This product is available on FluoroSeal® Sleeved and Lined Plug Valves in ANSI/ASME and DIN standards. In fact all DIN valves up to DN 150 come fitted with the EZ-SEAL® (patented) as standard. This innovation places FluoroSeal® Plug Valves at the leading edge of technology in the industrial valve market .

The EZ-SEAL® offers 360° simultaneous and even compression adjustment of the packing and plug, eliminating side loading. Visual indication takes the guess work out of valve adjustment and remaining service life diagnostic.

THE EZ-SEAL® CONCEPT

An easily accessible, single point frontal adjustment system that introduces the ease and precision of maintenance planning and cost savings on both manual and automated valve applications. Achievement is two-fold:

1. Maintenance technicians now have a trouble-free way of resealing both manual and automated valves with a single, quick and easy adjustment point (in comparison to time-consuming, cumbersome multiple adjustment bolt designs)
2. Visual gauging offers up-front knowledge of valve status, useful in scheduling valve change-out on shutdowns

ADVANTAGES

- No special tooling needed
- Significantly reduces recordable leakages
- Visual diagnostic
- Extended service life
- Allows for easy maintenance planning
- EZ-SEAL® Bracket and EZ-SEAL® Lock with a wide range of ISO mount patterns and five locking positions are offered in 304 SS as standard
- Allows direct mounting of actuation without inhibiting visual verification of stem status

DESIGN FEATURES SUMMARY

1. Single point frontal adjustment system
2. 360° simultaneous and even compression of top seal and plug
3. Plug adjustment is linear, impossible to side load
4. Tapered stem for increased sealing capabilities
5. Visual Min / Max cam adjustment indicator
6. Combination formed metal diaphragm and static eliminator
7. ISO mount stem
8. All-in-one ISO bracket and locking device, as standard
9. All components are high precision investment cast
10. Explosion-proof stem design
11. Positive shutoff



Valve with EZ-SEAL® (Patented) Assembly



EZ-SEAL® (Patented) Bracket and Lock

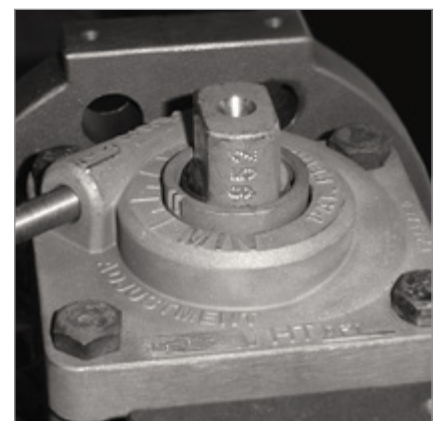

EZ-SEAL® (Patented) Cover with Cast On Min / Max Gauge

PLUG-SLEEVED-R003-2025

PLUG VALVES — OPTIONS



V-PORT & CHARACTERIZED PLUGS

FluroSeal® Plug Valves are also available with Characterized Plugs for fine control applications. Standard V-Ports in 60° and other custom configurations are available in all trim materials.

The design and features of the FluroSeal® Plug Valve makes it an excellent choice for fine throttling in slurry and chemical applications. The no cavity design allows the plug valve to throttle without exposing the stem seal to line pressure, a definite advantage over most ball valves specifically in high cycling applications.

The Cage Control V-Port Plug Valve is mostly used in highly abrasive applications offering the benefits of a metal seated control valve, with the added advantage of a bubble-tight shutoff at a fraction of the cost. This product is available in all materials from 1" to 14" (DN 25 to DN 150).

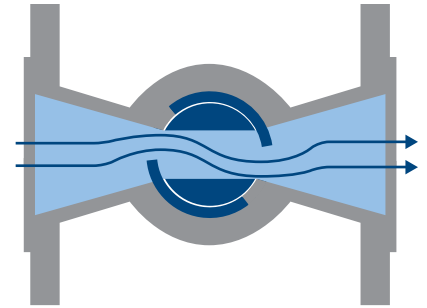

Flow Diagram



TYPICAL FLOW CHART FOR A 1" 60° V-PORT PLUG VALVE

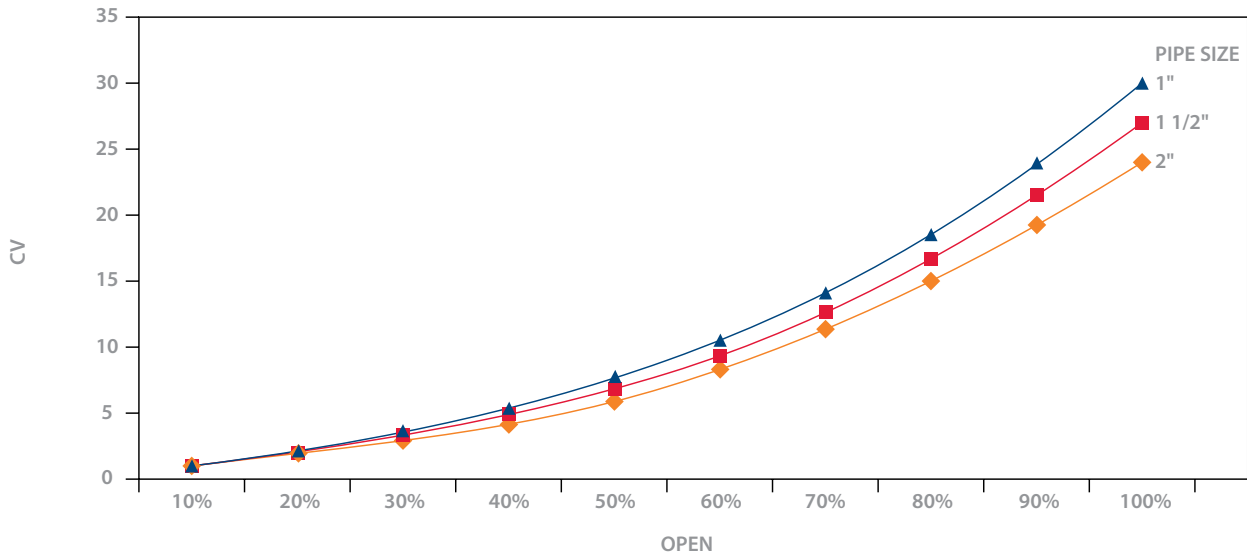

PLUG-SLEEVED-R003-2025

FluoroSeal

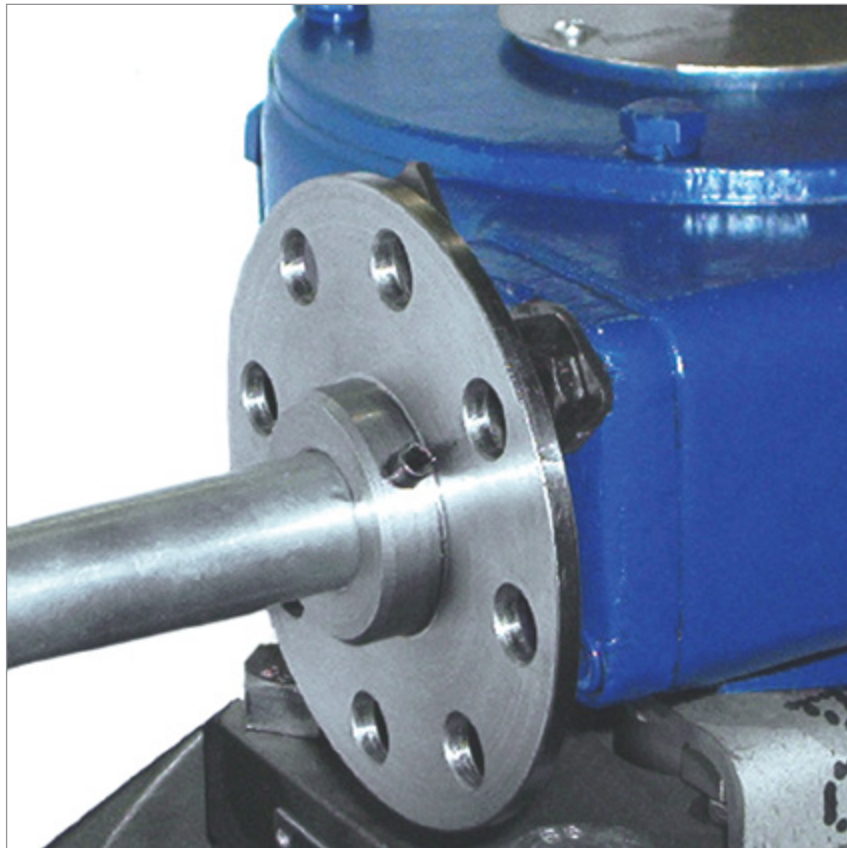

ACCESSORIES

ACCESSORIES

HANDWHEEL EXTENSION — GEAR OPERATOR

Custom extension to fit your particular space requirements. Please specify the length (L) needed. Support may be required depending on the length of the extension. (To be supplied by the customer.)

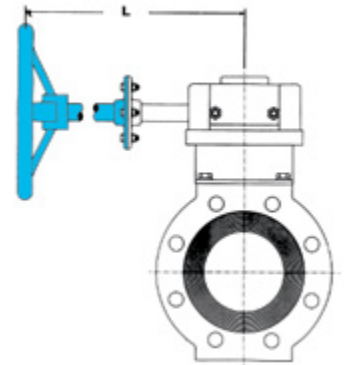

T-WRENCH AND EXTENSION OPTION

If longer "H" dimension, please specify.

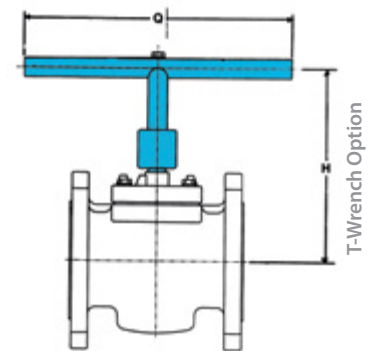

VALVE SIZE	1/2" (DN 15)		3/4" (DN 20)		1" (DN 25)		1 1/2" (DN 40)		2" (DN 50)		3" (DN 80)		4" (DN 100)	
	in	mm	in	mm	in	mm	in	mm	in	mm	in	mm	in	mm
Q	12.00	304.80	12.00	304.80	18.00	457.20	28.00	711.20	36.00	914.40	36.00	914.40	42.00	1066.80
H	6.80	172.72	6.80	172.72	7.40	187.96	8.00	203.20	8.40	213.36	9.00	228.60	9.60	243.84

CRANK HANDLE

VALVE SIZE	4" EG (DN 100)		6" EG (DN 150)		8" EG		10" EG		12" EG	
	in	mm	in	mm	in	mm	in	mm	in	mm
Q	7.25	184.15	7.25	184.15	9.75	247.65	9.75	247.65	13.75	349.25
H	10.75	273.05	11.50	292.10	13.00	330.20	15.50	393.70	17.25	438.15

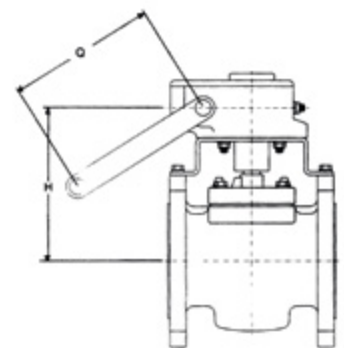

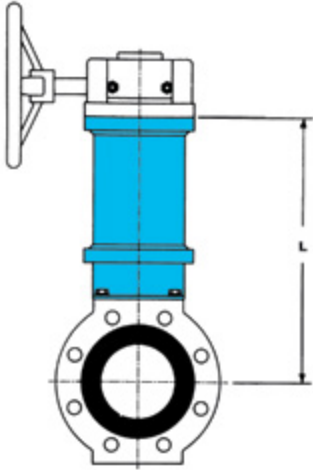

STEM EXTENSION — GEAR OPERATOR

Stem extensions are used for remote operation of the valve. Actuators can be attached to the top of the extension. Specify the length (L) of the extension required and the figure number of the valve it is to be attached to.

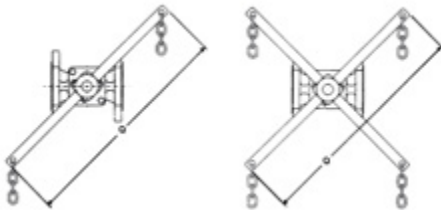

CHAIN WRENCH

Specify the chain length required and whether the valve will be installed in a horizontal or vertical line. To calculate chain length:

- 90° rotation: 1. Double required drop
2. Multiply Q by 0.5
3. 1+2 = required chain length
- 180° rotation: Double calculation for 90°

VALVE SIZE	1/2" (DN 15)		3/4" (DN 20)		1" (DN 25)		1 1/2" (DN 40)		2" (DN 50)		3" (DN 80)		4" (DN 100)	
	in	mm	in	mm	in	mm	in	mm	in	mm	in	mm	in	mm
Q	13.00	330.20	13.00	330.20	16.00	406.40	24.00	406.40	36.00	914.40	36.00	914.40	60.00	1524.00

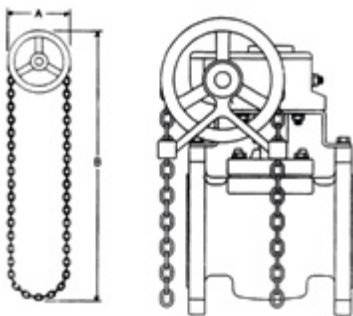

CHAIN WHEEL

Specify the chain length required and whether the valve will be installed in a horizontal or vertical line. To calculate chain length:

1. Double required drop B
2. Multiply chain wheel diameter A by 2.6
3. 1+2 = required chain length

WRENCH OPERATOR LOCKING DEVICE

Padlock is not supplied.

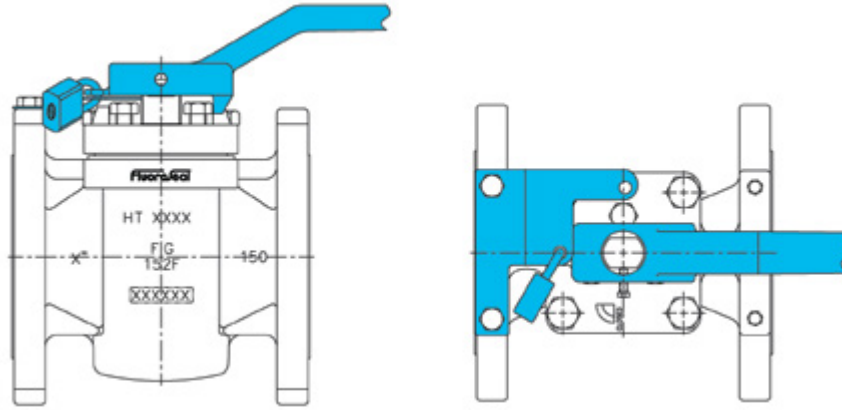

Locking Device on Regular Cover

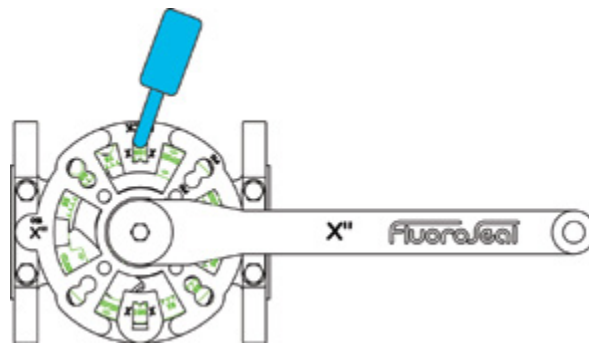

Locking Device on EZ-SEAL®

GEAR OPERATOR LOCKING DEVICE

Padlock is not supplied.

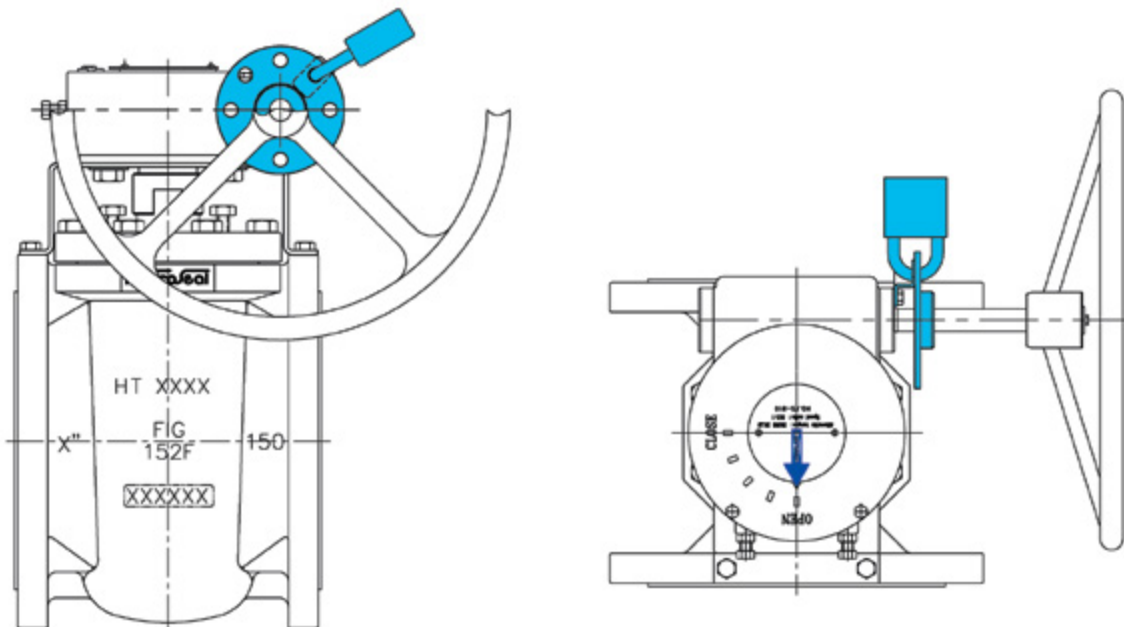

FluoroSeal



TECHNICAL DATA

TECHNICAL DATA



OUR ENGINEERING COMMITMENT

We will assist you in making the most appropriate selection of alloys and polymers to suit your application. We will provide you with CV factors and other necessary flow calculations, therefore making your decision process as easy as possible. We will work together with you to develop the best valve possible, no matter what your industry sector. Our Engineered Solutions Division (ESD) is staffed with highly skilled engineers, technicians and draftsmen specialized in modifying existing designs to meet your specific needs.

Please consult our website, www.fluorosealvalves.com, for the most up-to-date listing of torque and CV values.

QUALITY ASSURANCE

FluroSeal® Plug Valves possess all of the best design features presently available in a non-lubricated valve. They are inspected throughout the full manufacturing process from foundry to final assembly and packaging to assure high quality and consistency in every unit.

All internal processes are vetted according to best standard industry practices, inspections performed with equipment subject to periodic calibrations, and for special processes, such as welding, procedures and operators are fully qualified to the requirements of the ASME Boiler and Pressure Vessel Code, as well as to PED/CE requirements.

Please consult our website, www.fluorosealvalves.com, for the latest copy of our ISO, PED and AD Certificates.

TESTING

All FluroSeal® valves are pressure tested prior to shipment to ensure full compliance with ANSI B16.34 and MSS SP-61 (or DIN EN 12266-1) shell and seat test requirements. At customer option, API 598 requirements can also be met.

All high nickel alloy valves are also shell tested with helium on a standard basis. In addition, non-destructive tests such as radiographic, liquid penetrant or magnetic particle evaluations can be performed to various requirements, at customer option.



Chemical



Mining



Oil & Gas



Power Generation



Pulp & Paper

MATERIAL PROPERTIES

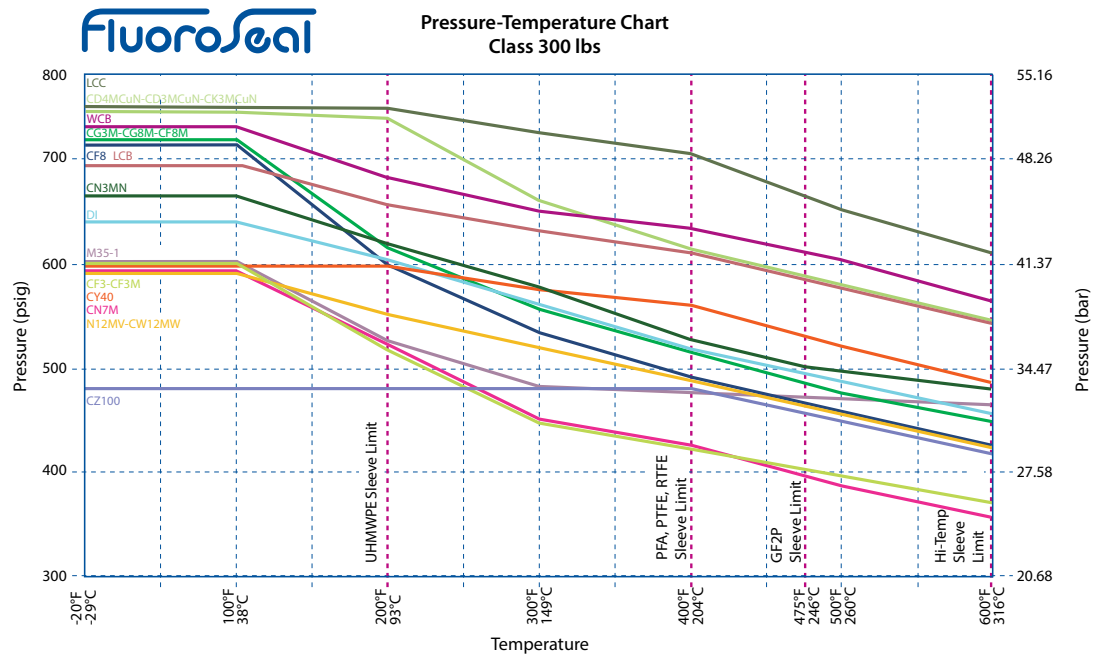
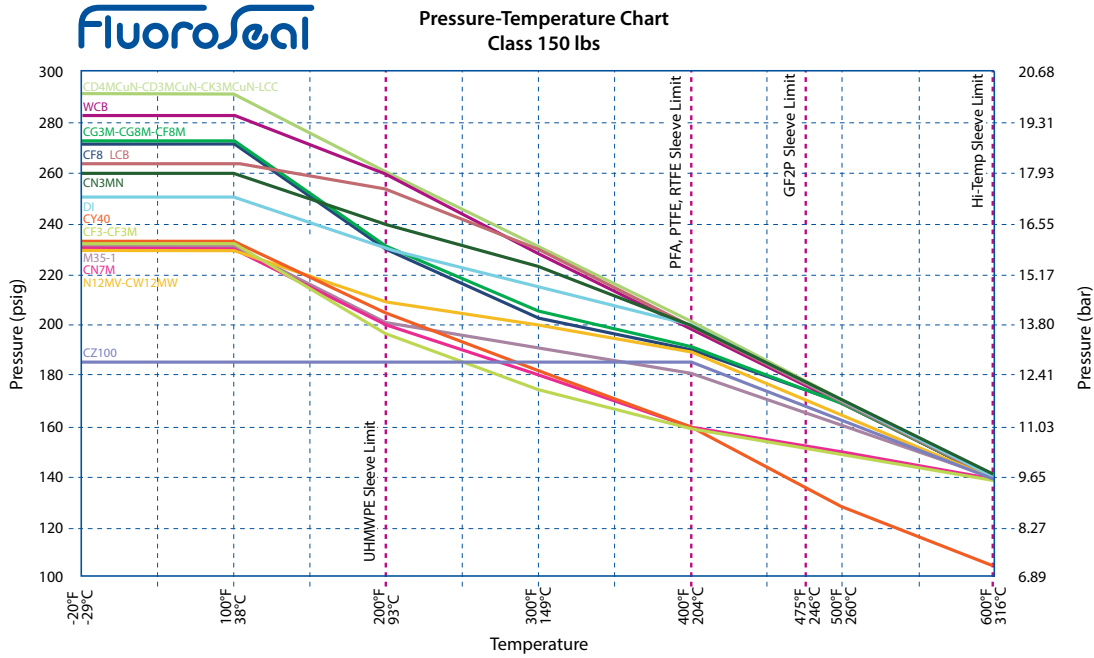

PLUG-SLEEVED-R003-2025

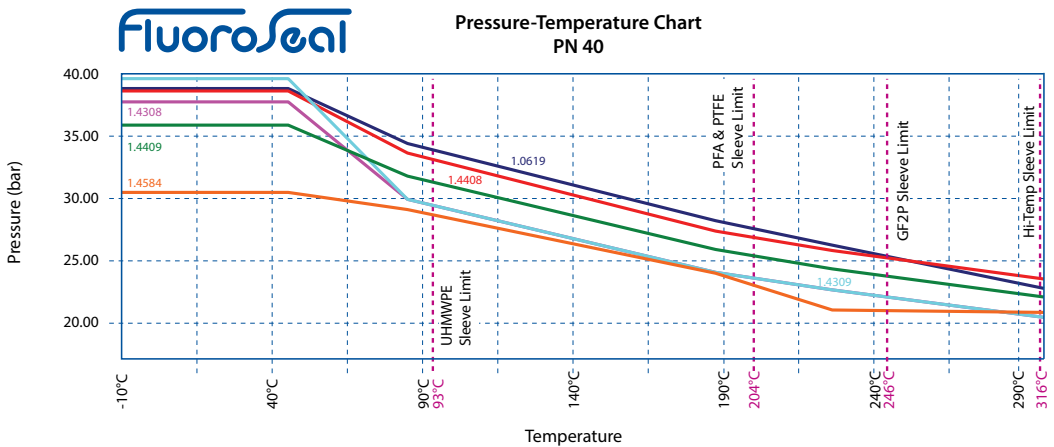
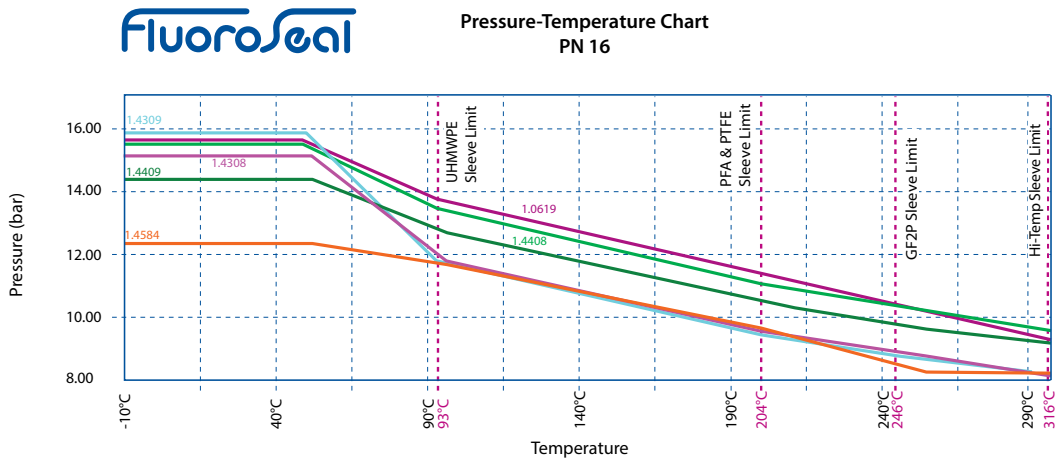
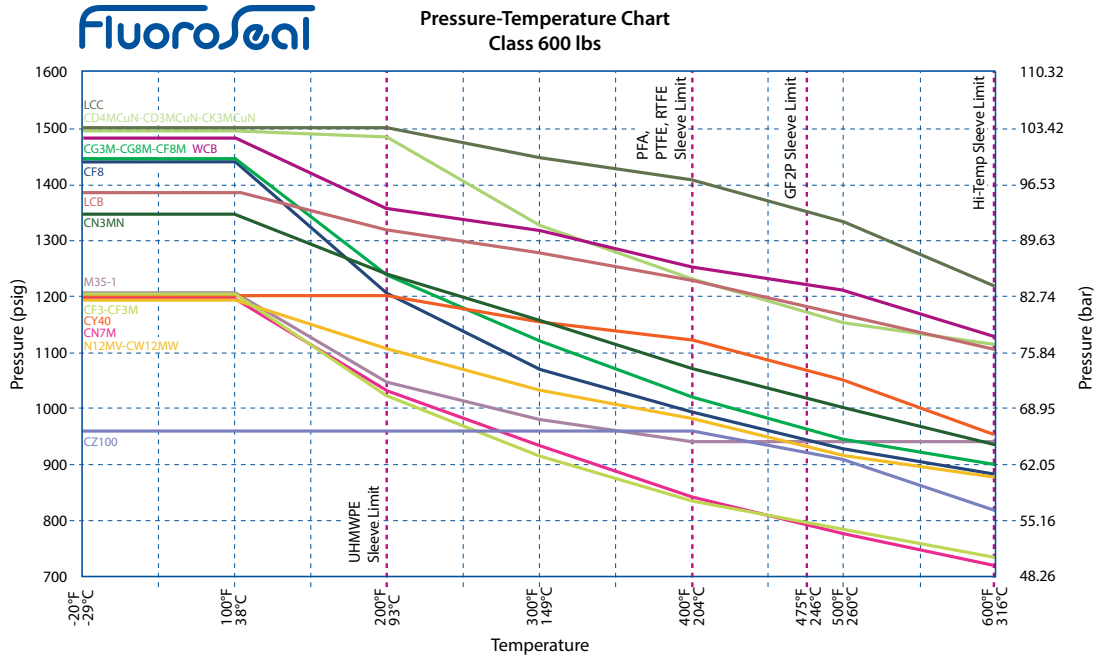

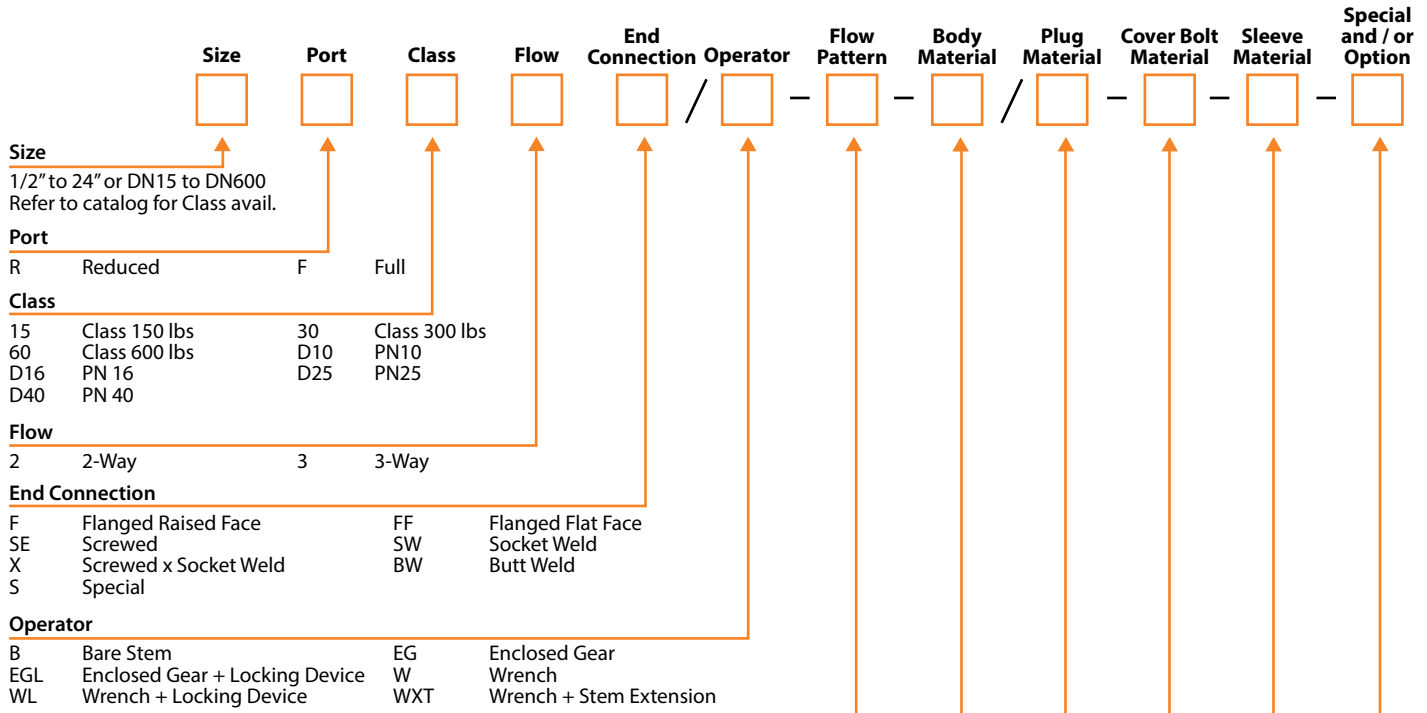

Size
1/2" to 24" or DN15 to DN600
Refer to catalog for Class avail.

Port
R Reduced F Full

Class
15 Class 150 lbs 30 Class 300 lbs
60 Class 600 lbs D10 PN10
D16 PN 16 D25 PN25
D40 PN 40

Flow
2 2-Way 3 3-Way

End Connection
F Flanged Raised Face FF Flanged Flat Face
SE Screwed SW Socket Weld
X Screwed x Socket Weld BW Butt Weld
S Special

Operator
B Bare Stem EG Enclosed Gear
EGL Enclosed Gear + Locking Device W Wrench
WL Wrench + Locking Device WXT Wrench + Stem Extension

Flow Pattern (Leave blank for 2-Way)
FA1, FA2, FA3, FA4, FA5 Refer to catalog for Flow Patterns

Body Material
Refer to Body & Plug Material Table

Plug Material
Refer to Body & Plug Material Table

Cover Bolt Material

1	B7*	2	B7M*
3	B8*	4	B16*
5	B8M Class 1*	6	B8M Class 2*
7	L7**	8	L7M**
9	B446 Gr.1	10	TC3
11	A20	12	A20 (Teflon Coated)
13	MO 400	14	HC
15	HC (Teflon Coated)	16	Inconel 718
17	TC5	18	ISO 898-1, 5.6
19	A2-70	20	A4-70
21	Special		

*According to ASTM A193 **According to ASTM A320

Sleeve Material

A	PFA	G	GF2P
P	PTFE	R	RTFE
U	UHMWPE	Z	Hi-Temp Teflon®

Special (A combination of Specials can be used)

- CL Prepared for Chlorine Service
- DBB Double Block & Bleed
- FE Severe Service
- HF UOP-Approved HF-Alkylation Configuration
- HOX Prepared for Hydrogen Peroxide
- ISY Prepared for Isocyanate Service
- OXY Prepared for Oxygen Service
- PHOS Prepared for Phosgene Service

Options (A combination of Options can be used)

CCV	Cage Control Valve	EZ	EZ-SEAL®
FJ	Full Jacket	FS	Fire Safe
PJ	Partial Jacket	V6	V-Port 60°
S	Special	— Description required	

VN(X,Y,Ø) Vented Plug (Specify Location (X,Y) and Diameter(Ø))
Special venting available on request

X: Upstream Y: T: Top Ø: 1/8
D: Downstream M: Middle 1/4
B: Bottom

BODY & PLUG MATERIAL TABLE

CODE	DESCRIPTION	ASTM DESIGNATION	DIN
WCB	Carbon Steel	A216 Gr. WCB	1.0619
LCB	Low Temp. Ferritic Alloy Steel	A352 Gr. LCB	1.6220
LCC	Low Temp. Ferritic Alloy Steel	A352 Gr. LCC	1.7219
304	304 Austenitic Stainless Steel	A351 Gr. CF8	1.4308
304L	304L Austenitic Stainless Steel	A351 Gr. CF3	1.4309
316	316 Austenitic Stainless Steel	A351 Gr. CF8M	1.4408
316L	316L Austenitic Stainless Steel	A351 Gr. CF3M	1.4409
317	317 Austenitic Stainless Steel	A351 Gr. CG8M	
317L	317L Austenitic Stainless Steel	A351 Gr. CG3M	
A20	Alloy 20	A351 Gr. CN7M	1.4500
904L	904L Stainless Steel	Cast Grade	1.4584
CD4N	Ferinox® 255 Super-Duplex S.S.	A995 Gr. 1B (CD4MCuN)	1.4517
CD3	2205 Super-Duplex S.S.	A995 Gr. 4A (CD3MN)	1.4470
CE3	2507 Super-Duplex S.S.	A995 Gr. 5A (CE3MN)	1.4417
CK3	254 SMO Super-Austenitic S.S.	A351 Gr. CK3MCuN	
CN3	AL-6XN Super-Austenitic S.S.	A351 Gr. CN3MN	
HB	HASTELLOY® B*	A494 Gr. N12MV	2.4685
HB2	HASTELLOY® B 2*	A494 Gr. N7M	2.4882
HC	HASTELLOY® C	A494 Gr. CW6M	2.4883
HC2	HASTELLOY® C 276*	A494 Gr. CW12MW	2.4686
I600	INCONEL® 600*	A494 Gr. CY40	2.4816
I625	INCONEL® 625*	A494 Gr. CW6MC	2.4856
MO	MONEL® 400	A494 Gr. M35-1	2.4365
NI	Nickel	A494 Gr. CZ-100	2.4170
TC2	Titanium (Comm. Pure)*	B367 Gr. C2	3.7035
TC3	Titanium (Comm. Pure)*	B367 Gr. C3	3.7031
TC5	Titanium Alloy 6Al-4V*	B367 Gr. C5	
ZR2	Zirconium*	B752 Gr. 702C	
ZR5	Zirconium*	B752 Gr. 705C	

Other and Special Alloys Available on Request
* Drilled and tapped flange actuation-mounting pads independent of cover and top seal assembly are optional on lever-operated valves (1/2" thru 4") in HASTELLOY®, INCONEL®, Titanium, and Zirconium alloys.

TERMS & CONDITIONS



CONTROLLING PROVISIONS

These terms and conditions shall control with respect to any purchase order or sale of FluoroSeal Inc.'s products. No waiver, alteration or modification of these terms and conditions whether on Buyer's purchase order or otherwise, shall be valid unless the waiver, alteration or modification is specifically accepted in writing and signed by an authorized representative of FluoroSeal Inc.

DELIVERY FluoroSeal Inc. will make every effort to complete delivery of products as indicated on its acceptance of an order, but FluoroSeal Inc. assumes no responsibility or liability, and will accept no back charge, for loss or damage due to delay or inability to deliver caused by acts of God, war, labor difficulties, accident, delays of carriers, by contractors or suppliers, inability to obtain materials, shortages of fuel and energy, or any other causes of any kind whatever beyond the control of FluoroSeal Inc. FluoroSeal Inc. may terminate any contract of sale of its products without liability of any nature, by written notice to Buyer, in the event that the delay in delivery or performance resulting from any of the aforesaid causes shall continue for a period of sixty (60) days. Under no circumstances shall FluoroSeal Inc. be liable for any special or consequential damages or for loss, damage, or expense (whether or not based on negligence) directly or indirectly arising from delays or failure to give notice of delay.

WARRANTY FluoroSeal Inc. warrants for one year from the date of shipment of its manufactured products to the extent that FluoroSeal Inc. will replace those having defects in material or workmanship when used for the purpose and in the manner which FluoroSeal Inc. recommends. If FluoroSeal Inc.'s examination shall disclose to its satisfaction that the products are defective, and an adjustment is required, the amount of such adjustment shall not exceed the net sale price of the defective product(s) only and no allowance will be made for labor or expense for repairing or replacing defective products or workmanship or damage resulting from the same. FluoroSeal Inc. warrants the products which it sells of other manufacturers to the extent of the warranties of their respective makers. Where engineering design or fabrication work is supplied, Buyer's acceptance of FluoroSeal Inc.'s design or of delivery of work shall relieve FluoroSeal Inc. of all further obligation, other than expressed in FluoroSeal Inc.'s product warranty.

THIS IS FLUOROSEAL INC.'S SOLE WARRANTY. FLUOROSEAL INC. MAKES NO OTHER WARRANTY OF ANY KIND, EXPRESSED OR IMPLIED, AND ALL IMPLIED WARRANTIES OF MERCHANTABILITY AND FITNESS FOR A PARTICULAR PURPOSE WHICH EXCEED THE AFORE STATED OBLIGATION ARE HEREBY DISCLAIMED BY FLUOROSEAL INC. AND EXCLUDED FROM THIS WARRANTY.

FluoroSeal Inc. neither assumes, nor authorizes any person to assume for it, any other obligation in connection with the sale of its engineering designs or products. This warranty shall not apply to any products or parts of products which (a) have been repaired or altered outside of FluoroSeal Inc.'s factory, in any manner; (b) have been subjected to misuse, negligence or accidents; (c) have been used in a manner contrary to FluoroSeal Inc.'s instructions or recommendations. FluoroSeal Inc. shall not be responsible for design errors due to inaccurate or incomplete information supplied by Buyer or its representatives.

LIABILITY FluoroSeal Inc. will not be liable for any loss, damage, cost of repairs, incidental or consequential damages of any kind, whether based upon warranty (except for the obligation accepted by FluoroSeal Inc. under "Warranty" above), contract or negligence, arising in connection with the design, manufacture, sale, use or repair of the products or of

the engineering designs supplied to Buyer. Any litigation will be interpreted in accordance with the laws of the Province of Québec, Canada and any suit, action or proceeding relating to these terms and conditions may be instituted in any competent court sitting in the district of Montréal, Québec, Canada.

RETURNS FluoroSeal Inc. cannot accept return of any product(s) unless its written permission has been first obtained, in which case same will be credited subject to the following: (a) all material returned must, on its arrival at FluoroSeal Inc.'s plant, be found to be in first-class condition; if not, cost of putting in saleable condition will be deducted from credit memoranda; (b) a restocking charge will apply based on the nature of the product returned, and will be deducted from all credit memoranda issued for material returned; (c) transportation charges, if not prepaid, will be deducted from credit memoranda.

SHIPMENTS All products sent out will be carefully examined, counted and packed. The cost of any special packing or special handling caused by Buyer's requirements or requests shall be added to the amount of the order. No claim for shortages will be allowed unless made in writing within ten (10) days of receipt of a shipment. Claims for products damaged or lost in transit should be made to the carrier, as FluoroSeal Inc.'s responsibility ceases, and title passes, on delivery to the carrier.

SPECIAL PRODUCTS Orders covering special or non-standard products are not subject to cancellation except on such terms as FluoroSeal Inc. may specify on application.

PRICES AND DESIGNS Prices and designs are subject to change without notice. All prices are F.O.B. Point of Shipment, unless otherwise stated.

TAXES The amount of any sales, excise or other taxes, if any, applicable to the products, shall be added to the purchase price and shall be paid by Buyer unless Buyer provides FluoroSeal Inc. with an exemption certificate acceptable to the taxing authorities.

NUCLEAR PLANTS Where the products, engineering design or fabrication is for nuclear plant applications, Buyer agrees (a) to take all necessary steps to add FluoroSeal Inc. as an insured under the American Nuclear Insurers (ANI) pool and under the Mutual Atomic Energy Reinsurance Pool (MAERP) for property damage and liability insurance and if necessary steps could have been taken, but are not taken, Buyer shall hold FluoroSeal Inc. harmless against all such losses which could have been thus covered; (b) Buyer agrees to hold FluoroSeal Inc. harmless with respect to any personal injury or death, property damage or any other loss in a nuclear incident which is caused directly or indirectly by defective design, material, or workmanship, furnished by FluoroSeal Inc. and which is covered by insurance maintained by Buyer (or which could be so covered but with respect to which Buyer has elected to self-insure), and further agrees to waive subrogation by its carriers of such insurance against FluoroSeal Inc.; (c) as to nuclear hazards for which Buyer cannot obtain insurance coverage, the liability of FluoroSeal Inc. for any personal injury or death, property damage or any other loss directly caused by defective design, material, or workmanship furnished by FluoroSeal Inc. shall not exceed the value of the material furnished by FluoroSeal Inc. at the time of the loss occurrence.

MINIMUM INVOICE \$250 plus shipping.

TERMS Cash, net 30 days unless otherwise specified.

Most recent terms and conditions are available in the Downloads section of our website.

FluoroSeal

www.fluorosealvalves.com